

Oracle Communications Diameter Signaling Router

Cloud Benchmarking Guide

Release 8.5.1

November 2022

Table of Contents

Introduction	6
References	6
Acronyms.....	6
Terminology	8
About Cloud Deployable DSR	9
What is a Cloud Deployable DSR?.....	9
Infrastructure Matters	10
Flexibility	10
Methodology	10
Benchmarking Cloud Deployable DSR.....	11
What to do with all this data?.....	11
Infrastructure Environment.....	12
General Rules for All Infrastructures.....	13
Hyper-Threading and CPU Over-Subscription	13
VM Packing Rate.....	14
Infrastructure Tuning	14
KVM (QEMU)/Oracle X5-2 – Infrastructure Environment.....	14
Device Drivers	15
BIOS Power Settings.....	15
Guest Caching Modes	15
Memory Tuning Parameters	16
VMware (ESXi) – Infrastructure Environment	17
Virtual Sockets vs. Cores per Virtual Socket.....	18
Network Settings	18
Power Settings	19
Hardware Assisted Virtualization	19
Virtual Machine Storage Configuration	19
Disk Provisioning.....	20
Benchmark Testing	20
DA MP Relay Benchmark	20
Overview	20
Topology	21
Message Flow	21
Large VM profile for DA-MP	22
Indicative Alarms/Events	22
DA-MP Indicators for Capacity Expansion.....	22
DA-MP Utilization	22
Measuring DA-MP Connection Utilization	24
Suggested Resolution	24
810K MPS Support	24
Overview	24
Full Address Based Resolution (FABR) Capacity.....	25

Overview	25
Topology	25
SDS DB Details	25
Message Flow	26
DP Indicators for Capacity Expansion	26
Measuring DP Utilization	27
Suggested Resolution	28
vSTP MP.....	28
Overview	28
vSTP MP Benchmarking	28
Note:	28
vSTP MP Indicators for Capacity Expansion	29
Utilization.....	29
Suggested Resolution	29
Policy DRA (PDRA) Benchmarking	29
Overview	29
Topology	30
Message Flow	31
Indicative Alarms/Events	32
Measurements	33
Suggested Resolution	33
Diameter Security Application (DSA) Benchmarking	34
Topology	34
Service Capability Exposure Function (SCEF) Benchmarking.....	37
Topology	37
Suggested Resolution	38
Equipment Identity Register (EIR)	38
NOAM.....	38
Overview	38
Indicative Alarms/Events	38
Measurements	39
Measuring Network OAM Utilization	39
Suggested Resolution	39
SOAM.....	39
Overview	39
Indicative Alarms/Events	39
Suggested Resolution	39
IPFE.....	39
Overview	39
Topology	40
Indicative Alarms/Events	40
Suggested Resolution	41
IDIH	41
Overview	41

Suggested Resolution	41
Appendix A. DSR VM Configurations	41
Appendix B. DSR VM Disk Requirements	44
Appendix C. VM Networking Requirements	45
Appendix D. Summary of Benchmark Data Recommendations.....	48
Appendix E. Detailed Infrastructure Settings	51
Appendix F. Small DSR VM Configuration	52
Appendix G. DSR DA-MP Profiles.....	53
Infrastructure Performance Differences	53
Traffic Mix	53
VM Configuration	54
Selecting a DA-MP Traffic Profile	54

List of Tables

Table 1: Acronyms	6
Table 2: Terminology	8
Table 3: Virtual Network Interrupt Coalescing and SplitRX Mode	18
Table 4: Power Management Profiles.....	19
Table 5: Virtualization Performance by Processor.....	19
Table 6: DA-MP Test Set Up	21
Table 7: DA-MP Alarms/Events	22
Table 8: DA-MP Utilization Metrics	22
Table 9: DA-MP Connection Metrics.....	24
Table 10: SDS DP Message Details	26
Table 11: SDS DP Alarms/Events	26
Table 12: SDS DP Utilization Metrics	27
Table 13: DP SOAM Metrics	27
Table 14: Feature-wise vSTP MP Benchmarking.....	28
Table 15: VSTP-MP Utilization Metrics.....	29
Table 16: PDRA Test Call Model	32
Table 17: SBR (b) Alarms/Events	32
Table 18: Session SBR (b) VMs Metrics.....	33
Table 19: Binding SBR (b) Server Metrics	33
Table 20: Stateful and Stateless Counter Measures	35
Table 21: 10K MPS DA-MP VM Profile with Regular UDR profile.....	36
Table 22: 30K MPS DA-MP VM Profile with Regular UDR profile.....	36
Table 23: UDR VM Profile.....	36
Table 24: DAMP combination with UDR Profile.....	36

Table 25: SCEF DA-MP Server Metrics.....	37
Table 26: Network OAM Metrics	39
Table 27: System OAM Metrics	39
Table 28: IPFE Throughput.....	40
Table 29: IPFE Metrics.....	40
Table 30: VM Configurations and Affinity Rules	41
Table 31: VM Disk Utilization Characteristics	44
Table 32: VM Networking Utilization Characteristics	46
Table 33: Typical OCDSR Network to Device Assignments.....	47
Table 34: Benchmark Data Summary.....	48
Table 35: Recommended Maximum Engineering Targets	48
Table 36: Detailed Infrastructure Settings.....	51
Table 37: Minimal System VM Configurations and Affinity Rules.....	52

List of Figures

Figure 1: DA-MP Testing Topology.....	21
Figure 2: DA-MP Message Sequence	21
Figure 3: SDS DP Testing Topology.....	25
Figure 4: SDS DP Message Sequence.....	26
Figure 5: SBR Testing Topology	30
Figure 6: PDRA Message Sequence	31
Figure 7: DSA Testing Topology	34
Figure 8: SCEF Testing Topology.....	37
Figure 9: EIR Testing Topology	38
Figure 10. IPFE on Ingress Side Only	40
Figure 11: IPFE on both Ingress and Egress Sides.....	40

Introduction

The Oracle Communications Diameter Signaling Router (OCDSR or DSR) is deployable in the cloud as a Virtual Network Function (VNF). With DSR's added flexibility of being cloud deployable, operators must be able to manage the capacity and performance of the DSR in the cloud.

This document focuses on:

- How to benchmark DSR performance and capacity in a cloud deployed DSR
- Provides recommendations on performance tuning the DSR
- Provides benchmark data from our labs
- Provides information on the key metrics used to manage DSR performance and capacity
- Provides recommendations on how to use the data obtained from the metrics

References

- [1] Performance Best Practices for VMware vSphere® 6.0 at <http://www.vmware.com/content/dam/digitalmarketing/vmware/en/pdf/techpaper/vmware-perfbest-practices-vsphere6-0-white-paper.pdf>

The following are available at Oracle.com on the Oracle Help Center (OHC):

- [2] DSR Alarms, KPIs, and Measurements
[3] DSR Cloud Deployable Installation Guide
[4] Policy and Charging Application User's Guide

Acronyms

Table 1: Acronyms

Acronym	Description
API	Application Programming Interface
ARR	Application Route Rule
ART	Application Route Table
CM	Counter Measure
COTS	Commercial Off The Shelf
CPU	Central Processing Unit
DA-MP	Diameter Agent Message Processor
DB	Database
DP	Database Processor
DSA	Diameter Security Application
DSR	Diameter Signaling Router
EIR	Equipment Identity Register
ETG	Egress Throttle Group
FABR	Full Address Based Resolution
FQDN	Fully Qualified Domain Name
GB	Gigabyte
HDD	Hard Disk Drive

Acronym	Description
HP	Hewlett Packard
HSS	Home Subscriber Server
HTTP	Hypertext Transfer Protocol
ID	Identification
IDIH	Integrated Diameter Intelligence Hub
IMI	Internal Message Interface
IMSI	International Mobile Subscriber Identity
I/O	Input/Output
IOP	Interoperability
IoT	Internet of Things
IP	Internet Protocol
IPCAN	Internet Protocol Connectivity Access Network
IPFE	IP Front End
KPI	Key Performance Indicator
KSM	Kernel Same-page Merging
KVM	Kernel-based virtual machine
LSI	Large Scale Integration
LTE	Long Term Evolution
MD-IWF	MAP-Diameter Interworking Function
MME	Mobility Management Entity
MNO	Mobile Network Operator
MP	Message Processor
MPS	Messages Per Second
MSISDN	Mobile Station International Subscriber Directory Number
MTC	Machine Type Communication
NIC	Network Interface Card
NOAM	Network Operations, Alarms, Measurements
NE	Network Element
OAM	Operations, Administration, and Maintenance
OCDSR	Oracle Communications Diameter Signaling Router
OCSG	Oracle Communications Services Gatekeeper
OHC	Oracle Help Center
PCRF	Policy and Charging Rules Function
PDRA	Policy Diameter Routing Agent
PRR	Peer Route Rule
PVSCSI	Paravirtual SCSI
RAM	Random Access Memory
RBAR	Range Based Address Resolution
SAS	Serial Attached SCSC

Acronym	Description
SCEF	Service Capabilities Exposure Function
SBR	Session Binding Repository
SBR(b)	SBR – subscriber binding database
SBR-g	
SBR(s)	SBR – session database
SBR(u)	SBR – universal database
SCS/AS	Service Centralization and Continuity Application Server
SCSI	Small Computer System Interface
SDS	Subscriber Database Server
SFF	Small Form Factor
SGSN	Serving GPRS Support Node
SMS	Short Message Service
SOAM	System (nodal) Operations, Alarms, Measurements
SS7	Signaling System #7
SSD	Solid State Drive
THP	Transparent Huge Pages
TSA	Target Set Address
TTP	Troubleshooting Trigger Point
vSTP	virtual Signaling Transfer Point
UDR-NO	User Data Repository Network OAM & Provisioning
U-SBR	Universal SBR
VM	Virtual Machine
VNF	Virtual Network Function
VoLTE	Voice over LTE
WAN	Wide Area Network
XMI	External Management Interface
XSI	External Signaling Interface

Terminology

Table 2: Terminology

Term	Description
1+1 Redundancy	For every 1, an additional 1 is needed to support redundant capacity. The specific redundancy scheme is not inferred (for example, active-active, and active-standby).
Geo-Diverse	Refers to DSR equipment located at geographically separated sites/datacenters
Geo-Redundant	A node at a geo-diverse location which can assume the processing load for another DSR signaling node(s)
Ingress Message Rate	A measure of the total Diameter messages per second ingressing the DSR. For this measure, a message is defined as any Diameter message that DSR reads from a Diameter peer connection independent of how the message is processed by the DSR.

Term	Description
Messages Per Second	<p>A measure of the DSR Diameter message processing volume in messages per second. For this measure, a message is defined as:</p> <ul style="list-style-type: none"> DSR processing of an ingress Diameter message and either transmitting a single outgoing Diameter message or discarding the ingress message. The outgoing message may be a variant of, or a response to, the ingress message. DSR transmission of any Diameter message, as required by DSR configuration, that is associated with incremental actions/events associated with #1 above. For example, the re-routing of a Request upon connection failure or the copying of a Request. <p>Messages excluded from this measure are:</p> <ul style="list-style-type: none"> Diameter peer-to-peer messages: CER/CEA, DWR/DWA, and DPR/DPA Ingress Diameter messages discarded by the DSR due to Overload controls Answers received in response to Message Copy <p>For the vSTP MP the MPS excludes the equivalent SSNM status management messages.</p>
N+K Redundancy	For every N, an additional K is needed to support redundant capacity. The specific redundancy scheme is not inferred (for example, active-active, active-standby).
Node	A DSR node is a DSR signaling node (SOAM and subtending topology), an NOAM node or an SDS node. A node is synonymous with the network element (NE).
Site	A specific geographic location or datacenter where DSR application is installed.

About Cloud Deployable DSR

DSR is deployed on a number of platforms. The DSR has a multiple deployment scenarios:

- Bare-metal and hybrid (mixture of bare metal and virtual machines) — is the original deployment configuration of the DSR. It scales to very high performance and is widely deployed.
- Fully virtualized — was introduced shortly after bare-metal. It provides virtualization of the DSR, but does not use a cloud manager, and does not co-reside with other applications. Provides a compact, cost-effective footprint and is widely deployed.
- Cloud deployable – It provides full virtualization, assumes the DSR resources are managed by a COTS cloud manager, and the DSR can be one of many applications in the cloud. Cloud deployable DSR is the focus of this document.
- Mix and match – DSR is a network of DSR signaling sites. The deployment infrastructure at each site can vary, for example, bare-metal at one site, and then cloud deployed at another location.

What is a Cloud Deployable DSR?

A DSR that is ready and able to be deployed into a number of different cloud environments, including but not limited to:

- A customer provided cloud infrastructure. The DSR is simply one of many applications.
- A dedicated private cloud. The DSR may be the only application, or one of a small set of applications. Services and infrastructure may also be provided by Oracle and deployed at customer's sites. Often (but not necessarily) this is a deployment tuned specifically for the DSR.
- A hosted cloud. The DSR is deployed in an Oracle or operator hosting cloud, and end-customers rent or lease the DSR application from the hosting provider.

Infrastructure Matters

The DSR is capable of running on a huge variety of infrastructures, but not all infrastructures are the same. The performance, capacity, and latency of the DSR can vary dramatically based on the chosen infrastructure and how it is deployed. In general, the DSR works best in a high bandwidth, low-latency, high processing power environment (carrier grade cloud). Some considerations that impact DSR performance, capacity, latency:

- Hardware – the CPUs and NICs (network interface cards)
- Hypervisor settings/configuration
- Uplinks, switches, WAN latency
- Storage configuration (local, networked)

DSR has excellent high availability and geo-diversity resiliency mechanisms that work in concert with cloud manager capabilities. Obviously, the needed scale, availability, and resiliency of the deployment also impact the resource and infrastructure requirements.

Flexibility

DSR is flexibly deployed into many different clouds. It is unlikely that any two clouds are exactly the same and operators need to optimize for different reasons (for example, power consumption may be critical for one operator, and WAN latency at another), varying sets of applications, and differing operational requirements. The performance and capacity of the DSR varies in each cloud, and the DSR application can no longer provide a guaranteed level of performance and capacity. However, the operator still needs to:

- Plan their networks – DSRs use resources, what impact DSR has on their datacenters?
- Deploy DSR with predictable (if not exact) performance and capacity.
- Manage the capacity and performance of the DSR in their datacenters.

Methodology

There is a set of DSR specific tools, methods and documentation to assist in planning, deploying, and managing the capacity and performance of a cloud deployable DSR. This toolset is expected to be used in conjunction with information and tools provided by the infrastructure (hardware, cloud manager, hypervisor) vendors.

- Planning for cloud deployable DSR
 - Estimating required resources for a given DSR cloud deployment
 - Please contact your Oracle Sales Consultant. They have access to the DSR Cloud Dimensioning tool which estimates DSR cloud resources. This tool takes into account many factors not covered in this benchmarking guide, such as the overhead for optional DSR features not covered in the benchmarking guide, and recommended margins for redundancy.
 - DSR Cloud Customer Documentation
 - Can be found with the DSR customer documentation at Oracle.com on the Oracle Help Center (OHC).
 - Look under the topic: “Cloud Planning, Installation, Upgrade, and Disaster Recovery.”
- Deploy DSR with predictable performance and capacity
 - It is recommended that the DSR is run through a benchmark on the target cloud infrastructure to determine the likely capacity and performance in the target infrastructure. This information can



then be used to adjust the initial deployment resources (if needed), and to help predict future resource requirements if and when the DSR grows.

- This document provides information on how to benchmark DSR performance and capacity. It also provides comprehensive benchmark results for a few select infrastructures. More benchmark data will be added to the document as it becomes available.
- This document also provides performance recommendations and observed differences for performance tuning decisions.
- Manage the capacity and performance of the DSR
 - The customer network is always changing- traffic patterns change, new applications are introduced. The infrastructure changes – new hardware, software/firmware updates. The operator needs to monitor and adjust the DSR resources for the changing conditions of the network and infrastructure.
 - This document provides the key metrics and recommendations for monitoring the capacity and performance of a cloud deployed DSR.

Benchmarking Cloud Deployable DSR

This document is divided into several sections:

- Infrastructure Environment. This section provides details of the infrastructures used for the benchmark testing, including the hardware and software. It also describes key settings and attributes, and some recommendations on configuration.
- A benchmark section for each DSR server type. Each DSR server type is given independent treatment for its benchmark. Each section describes the traffic setup, and the observed results. It also provides metrics and guidelines for assessing performance on any infrastructure.

What to do with all this data?

This data is intended to provide guidance. Recommendations may need to be adapted to the conditions in a given operator's network. Each section below provides metrics that provide feedback on the running performance of the application.

When planning to deploy a DSR into any cloud environment, a few steps are recommended:

- Understand the initial deployment scenario for the DSR. Which features are planned, how much of what type of traffic? Of course, this may change once deployed, and the DSR can be grown or shrunk to meet the changing needs.
- Use the DSR cloud dimensioning tool to get an estimate of the types of DSR virtual servers needed, and an initial estimate of the quantity of the virtual machines and resources. Your Oracle Sales Consultant can run this tool for you based on your DSR requirements:
 - The tool allows for a very detailed model to be built of your DSR requirements including:
 - Required MPS by Diameter Application ID (S6a, Sd, Gx, Rx, etc.).
 - Required DSR applications such as Full Address Based Resolution (FABR) and Policy DRA (PDRA) and any required sizing information such as the number of subscribers supported for each application.
 - Any required DSR features such as Topology Hiding, Message Copy, IPSEC, or Mediation that can affect performance.
 - Network-level redundancy requirements, such as mated pair DSR deployments where one DSR needs to support full traffic when one of the DSRs is unavailable.
 - Infrastructure information such as VMware vs. KVM, and Server parameters.
 - The tool then generates a recommended number of VMs for each of the required VM types.

- As noted below, these recommendations are just guidelines, since the actual performance of the DSR can vary significantly based on the details of the infrastructure.
- Based on the initial deployment scenario, determine if additional benchmarking is warranted:
 - For labs and trials, there is no need to benchmark performance and capacity if the goal of the lab is to test DSR functionality.
 - If the server hardware is different from the hardware used in this document then the performance differences can likely be estimated using industry standard metrics comparing single-threaded processor performance of the CPUs used in this document versus the CPUs used in the customer's infrastructure. This approach is most accurate for small differences in hardware (for instance, different clock speeds for the same generation of Intel processors) and least accurate across processor generations where other architectural differences such as networking interfaces could also affect the comparison.
 - It is the operator's decision to determine if additional benchmarking in the operator's infrastructure is desired. Here's a few things to consider when deciding:
 - Benchmark infrastructure is similar to the operator's infrastructure, and the operator is satisfied with the benchmark data provided by Oracle.
 - Initial turn-up of the DSR is handling a relatively small amount of traffic and the operator prefers to measure and adjust once deployed.
 - Operator is satisfied with the high-availability and geo-diversity of the DSR, and is willing to risk initial overload conditions, and adjusts once the DSR is production.
- If desired, execute benchmarking testing on the target cloud infrastructure. Only benchmark those types of DSR servers needed for the deployment (for example, if full address resolution is not planned, don't waste time benchmarking the SDS, SDS SOAM, or DPs).
 - Once that benchmarking is completed, take a look at the data for each server type, and compare it to the baseline used for the estimate (from the cloud dimensioning tool).
 - If the performance estimate for a given DSR function is X and the observed performance is Y, then adjust the performance for that DSR function to Y.
 - Recalculate the resources needed for deployment based on the updated values.
- Deploy the DSR.
- Monitor the DSR performance and capacity as described later in the document. As the network changes additional resources may be required. Increase the DSR resources as described later in this document as needed.

Infrastructure Environment

This section describes the infrastructure that was used for benchmarking. In general, the defaults or recommendations for hypervisor settings are available from the infrastructure vendors (for example, ESXi vendor recommendations and defaults found in [[1]]). Whenever possible the DSR recommendations align with vendor defaults and recommendations. Benchmarking was performed with the settings described in this section. Operators may choose different values; better or worse performance compared to the benchmarks may be observed. When recommendations other than vendor defaults or recommendations are made, additional explanations are included in the applicable section.

There is a subsection included for each infrastructure environment used in benchmarking.

General Rules for All Infrastructures

Hyper-Threading and CPU Over-Subscription

All of the tests were conducted with Hyper-Threading enabled, and a 1:1 subscription ratio for vCPUs in the hypervisor. The hardware used for the testing were dual-processor servers with 18 physical cores each (Xeon E5-2699v3). Thus, each server had:

$$(2 \text{ CPUs}) \times (18 \text{ cores per CPU}) \times (2 \text{ threads per core}) = 72 \text{ vCPUs}$$

It is not recommended to use over-subscribed vCPUs (for instance 4:1) in the hypervisor. Not only is the performance lower, but it makes the performance more dependent on the other loads running on each physical server.

Turning off Hyper-Threading is also not recommended. There is a small increase in performance of a given VM without Hyper-Threading for a given number of vCPUs. But since the number of vCPUs per processor drops in half without Hyper-Threading, the overall throughput per server also drops almost by half.

The vCPU sizing per VM is provided in section DSR VM Configurations.

Recommendation: Hyper-Threading enabled and 1:1 CPU subscription ratio.

CPU Technology

The CPUs in the servers used for the benchmarking were the Intel Xeon E5-2699v3. Servers with different processors are going to give different results. In general there are two issues when mapping the results of the benchmarking data in this document to other CPUs:

1. The per-thread performance of a CPU is the main attribute that determines VM performance since the number of threads is fixed in the VM sizing as shown in section DSR VM Configurations. A good metric for comparing the per-thread performance of different CPUs is the integer performance measured by the SPECint2006 (CINT2006) defined by SPEC.ORG. The mapping of SPECint2006 ratios to DSR VM performance ratios isn't exact, but it's a good measure to determine whether a different CPU is likely to run the VMs faster or slower than the benchmark results in this document. Conversely CPU clock speeds are a relatively poor indicator of relative CPU performance. Within a given Intel CPU generation (v2, v3, v4, etc.) there are other factors that affect per-thread performance such as potential turbo speeds of the CPU vs. the cooling solution in a given server. Comparing between Intel CPU generations there is a generation over generation improvement of CPU throughput vs. clock speed that means that even a newer generation chip with a slower clock speed may run a DSR VM faster.
2. The processors must have enough cores that a given VM can fit entirely into a NUMA node. Splitting a VM across NUMA nodes greatly reduces the performance of that VM. The largest VM size (see section DSR VM Configurations) is 12 vCPUs. Thus, the smallest processor that should be used is a 6 core processor. Using processors with more cores typically makes it easier to "pack" VMs more efficiently into NUMA nodes, but should not affect individual VM CPU-related performance otherwise (see the next note though).
3. One caveat about CPUs with very high core counts is that the user must be aware of potential bottlenecks caused by many VMs contending for shared resources such as network interfaces and ephemeral storage on the server. These tests were run on relatively large CPUs (18 physical cores per chip), and no such bottlenecks were encountered while running strictly DSR VMs. In clouds with VMs from other applications potentially running on the same physical server as DSR VMs, or in future processor generations with much higher core counts, this potential contention for shared server resources has to be watched closely.

Recommendation: The selected VM sizes should fit within a single NUMA node (for instance 6 physical cores for the VMs that required 12 vCPUs. Check the performance of the target CPU type against the benchmarked CPU using per-thread integer performance metrics.

VM Packing Rate

The OCDSR doesn't require or use CPU pinning. Thus the packing of the OCDSR VMs onto the physical servers is under the control of OpenStack using the affinity/anti-affinity rules given in DSR VM Configurations. Typically, the VMs do not fit exactly into the number of vCPUs available in each NUMA node, leaving some un-allocated vCPUs. The ratio of the allocated to the unallocated vCPUs is the VM Packing Ratio. For instance, on a given server if 60 out of 72 vCPUs on a server were allocated by the OpenStack, that server would have a packing ratio of ~83%. The achieved packing in a deployment depends on a lot of factors, including the mix of large VMs (DA-MPs, SBRs) with the smaller VMs, and whether the OCDSR is sharing the servers with other applications that have a lot of large or small VMs. When planning the number of physical servers required for an OCDSR a target packing ratio of 80% is a good planning number. A packing ratio of 100% is hard to achieve and may affect the performance numbers shown in the benchmarks. Some amount of server capacity is necessary to run the Host OS for the VMs, performing functions such as interrupt handling. A packing ratio of 95% or lower is desirable.

Recommendation: When planning for physical server capacity a packing ratio of 80% is a good guideline. Packing ratios of greater than 95% might affect the benchmark numbers since there aren't sufficient server resources to handle the overhead of Host OSs.

Infrastructure Tuning

The following parameters should be set in the infrastructure to improve DSR VM performance. The instructions for setting them for a given infrastructure is including the DSR Cloud Installation Guide [[3]].

- TxqueueLen: The default of 500 is too small. Recommendation is to set this parameter to 30,000.
 - Tuned on the compute hosts.
 - Default value of 500 is too small. Our recommendation is to set to 30000. This increases the network throughput of a VM.
- Ring buffer increase on the physical Ethernet interfaces: The default is too small. The recommendation is to set both receive and transmit values to 4096.
- Multiqueue: Multiqueue should be enabled on any IPFE VMs to improve performance. Already enabled by default on ESXi, needs to be set for Openstack.
- Advanced NUMA settings (ESXi only): The SwapLoadEnabled and SwapLocalityEnabled options should be disabled. This prevents the ESXi scheduler from moving VMs around from one NUMA node to another trying to optimize performance. These settings aren't appropriate for VMs that are processing real-time loads since messages might be delayed during the move.

Recommendation: Follow instructions in the DSR Installation Guide.

KVM (QEMU)/Oracle X5-2 – Infrastructure Environment

There are a number of settings that affect performance of the hosted virtual machines. A number of tests were performed to maximize the performance of the underlying virtual machines for the DSR application.

Host Hardware

- Oracle Server X5-2
 - CPU Model: Intel® Xeon® CPU E5-2699 v3 @ 2.30GHz
 - 2 CPUs
 - 18 physical cores per CPU
 - RAM: 128 GB
 - HDD: 2.3 TB of solid state drive (SSD) storage

- NIC:
 - 4 x Intel Ethernet Controller 10-Gigabit x540-AT2

Hypervisor

- QEMU-KVM Version: QEMU 1.5.3, libvirt 1.2.8, API QEMU 1.2.8

Device Drivers

VirtIO is a virtualizing standard for network and disk device drivers where just the guest's device driver "knows" it is running in a virtual environment, and cooperates with the hypervisor. This enables guests to get high performance network and disk operations, and gives most of the performance benefits of para-virtualization.

Vhost-net provides improved network performance over Virtio-net by totally bypassing QEMU as a fast path for interruptions. The vhost-net runs as a kernel thread and interrupts with less overhead providing near native performance. The advantages of using the vhost-net approach are reduced copy operations, lower latency, and lower CPU usage.

Recommendation: Vhost-net driver is recommended.

BIOS Power Settings

Typical BIOS power settings (hardware vendor dependent, see your infrastructure hardware vendor documentation for details) provide three options for power settings:

- Power Supply Maximum: The maximum power the available PSUs can draw
- Allocated Power: The power is allocated for installed and hot pluggable components
- Peak Permitted: The maximum power the system is permitted to consume

Recommendation: Set to Allocated Power or equivalent for your Hardware vendor

Disk Image Formats

The two preferred disk image file formats available when deploying a KVM virtual machine:

- QCOW2: Disk format supported by the QEMU emulator that can expand dynamically and supports Copy on Write.
- Raw Dump Representation: Unstructured disk image format.

QCOW2 provides a number of benefits over raw dump such as:

- Smaller file size, even on filesystems which don't support holes (such as, sparse files)
- Copy-on-write support, where the image only represents changes made to an underlying disk image
- Snapshot support, where the image can contain multiple snapshots of the images history

The recommended Container format is "bare" – no container or metadata envelope for the disk image. The container format string is not currently being used by OpenStack components.

Recommendation: QCOW2 (Since DSR does not involve processes which are disk I/O intensive.)

Recommendation: Bare Container format

Guest Caching Modes

The operating system maintains a page cache to improve the storage I/O performance. With the page cache, write operations to the storage system are considered completed after the data has been copied to the page cache. Read operations can be satisfied from the page cache if the data requested is in the cache. The page cache is copied to permanent storage using fsync. Direct I/O requests bypass the page

cache. In the KVM environment, both the host and guest operating systems can maintain their own page caches, resulting in two copies of data in memory.

The following caching modes are supported for KVM guests:

- **Writethrough:** I/O from the guest is cached on the host but written through to the physical medium. This mode is slower and prone to scaling problems. Best used for a small number of guests with lower I/O requirements. Suggested for guests that do not support a writeback cache (such as, Red Hat Enterprise Linux 5.5 and earlier), where migration is not needed.
- **Writeback:** With caching set to writeback mode, both the host page cache and the disk write cache are enabled for the guest. Because of this, the I/O performance for applications running in the guest is good, but the data is not protected in a power failure. As a result, this caching mode is recommended only for temporary data where potential data loss is not a concern.
- **None [Selected]:** With caching mode set to none, the host page cache is disabled, but the disk write cache is enabled for the guest. In this mode, the write performance in the guest is optimal because write operations bypass the host page cache and go directly to the disk write cache. If the disk write cache is battery-backed, or if the applications or storage stack in the guest transfer data properly (either through fsync operations or file system barriers), then data integrity can be ensured. However, because the host page cache is disabled, the read performance in the guest would not be as good as in the modes where the host page cache is enabled, such as write through mode.
- **Unsafe:** The host may cache all disk I/O, and sync requests from guest are ignored.

Caching mode None is recommended for remote NFS storage, because direct I/O operations (O_DIRECT) perform better than synchronous I/O operations (with O_SYNC). Caching mode None effectively turns all guest I/O operations into direct I/O operations on the host, which is the NFS client in this environment. Moreover, it is the only option to support migration.

Recommendation: Caching Mode = None

Memory Tuning Parameters

Swappiness

The swappiness parameter controls the tendency of the kernel to move processes out of physical memory and onto the swap disk. Because disks are much slower than RAM, this can lead to slower response times for system and applications if processes are too aggressively moved out of memory.

- `vm.swappiness = 0:` The kernel swaps only to avoid an out of memory condition.
- `vm.swappiness = 1:` Kernel version 3.5 and over, as well as kernel version 2.6.32-303 and over; Minimum amount of swapping without disabling it entirely.
- `vm.swappiness = 10:` This value is recommended to improve performance when sufficient memory exists in a system.
- `vm.swappiness = 60:` Default
- `vm.swappiness = 100:` The kernel swaps aggressively.

Recommendation: `vm.swappiness = 10`

Kernel Same Page Merging

Kernel Same-page Merging (KSM), used by the KVM hypervisor, allows KVM guests to share identical memory pages. These shared pages are usually common libraries or other identical, high-use data. KSM allows for greater guest density of identical or similar guest operating systems by avoiding memory duplication. KSM enables the kernel to examine two or more already running programs and compare their memory. If any memory regions or pages are identical, KSM reduces multiple identical memory pages to a single page. This page is then marked copy on write. If the contents of the page is modified by a guest virtual machine, a new page is created for that guest.



This is useful for virtualization with KVM. When a guest virtual machine is started, it only inherits the memory from the host qemu-kvm process. Once the guest is running, the contents of the guest operating system image can be shared when guests are running the same operating system or applications. KSM allows KVM to request that these identical guest memory regions be shared.

KSM provides enhanced memory speed and utilization. With KSM, common process data is stored in cache or in main memory. This reduces cache misses for the KVM guests, which can improve performance for some applications and operating systems. Secondly, sharing memory reduces the overall memory usage of guests, which allows for higher densities and greater utilization of resources.

The following 2 Services control KSM:

- **KSM Service:** When the KSM service is started, KSM shares up to half of the host system's main memory. Start the KSM service to enable KSM to share more memory.
- **KSM Tuning Service:** The ksmtuned service loops and adjusts KSM. The ksmtuned service is notified by libvirt when a guest virtual machine is created or destroyed.

Recommendation: KSM service set to active and ksmtuned service running on KVM hosts.

Zone Reclaim Mode

When an operating system allocates memory to a NUMA node, but the NUMA node is full, the operating system reclaims memory for the local NUMA node rather than immediately allocating the memory to a remote NUMA node. The performance benefit of allocating memory to the local node outweighs the performance drawback of reclaiming the memory. However, in some situations reclaiming memory decreases performance to the extent that the opposite is true. In other words, in these situations, allocating memory to a remote NUMA node generates better performance than reclaiming memory for the local node.

A guest operating system causes zone reclaim in the following situations:

- When you configure the guest operating system to use huge pages.
- When you use KSM to share memory pages between guest operating systems.

Configuring huge pages and running KSM are both best practices for KVM environments. Therefore, to optimize performance in KVM environments, it is recommended to disable zone reclaim.

Recommendation: Disable Zone Reclaim.

Transparent Huge Pages

Transparent huge pages (THP) automatically optimize system settings for performance. By allowing all free memory to be used as cache, performance is increased.

Recommendation: Enable THP.

VMware (ESXi) – Infrastructure Environment

There are a number of ESXi (VMware hypervisor) settings that affect performance of the hosted virtual machines. A number of tests were performed to maximize the performance of the underlying virtual machines for the DSR application.

- Hypervisor versions tested
- ESXi 5.5
- ESXi 6.0 U2

Virtual Sockets vs. Cores per Virtual Socket

When defining a virtual machine the number of vCPUs must be assigned to a server. The user has options for setting the number of “Virtual Sockets” and the number of “Cores per Virtual Socket”. The product of these two parameters determines the number of vCPUs available to the virtual machine.

In following the VMware best practices, the default value of 1 core per socket was used. This configuration is referred to as “wide” and “flat.” This enables vNUMA to select and present the best virtual NUMA topology to the guest operating system, which is optimal on the underlying physical topology.

Recommendation: 1 core per socket, virtual socket set to the number of vCPUs required by the server role.

Network Settings

Network Adapters

There is a number of networking adapter choices when deploying a virtual machine:

- E1000: This adapter is an emulated version of Intel 82545EM Gigabit Ethernet Controller. VMXNET3 adapter is the next generation of Para virtualized NIC designed for performance.
- VMXNET3: This adapter has less CPU overhead compared to e1000 or e1000e. Also, VMXNET3 is more stable than e1000 or e1000e. VMXNET3 adapter is the next generation of Para virtualized NIC designed for performance. This is the vSphere default setting.
- VMXNET family implements an idealized network interface that passes network traffic between the virtual machine and the physical network interface cards with minimal overhead.

Recommendation: VMXNET3. No observable differences were noticed between E1000 and VMXNET3 for DSR application testing.

Virtual Network Interrupt Coalescing and SplitRx Mode

- Virtual network Interrupt Coalescing: This option reduces number of interrupts thus potentially decreasing CPU utilization. This may however increase network latency. By default this is enabled in ESX 5.5 and 6.0.
- SplitRxMode: This option uses multiple physical CPUs to process network packets received in single network queue. By default this is enabled in ESX 5.5 and 6.0 for VMXNET3 adapter type.

Table 3: Virtual Network Interrupt Coalescing and SplitRX Mode

Network Setting	Default	Virtual Network Interrupt Coalescing: Disabled	SplitRxMode: Disabled
DSR.CPU (Avg/Max)	~40.7%/~44.5%	~42%/~45.5%	~38.8%/~40.6%
System.CPU_UtilPct (Avg/Max)	~44.4%/~53%	~44.4%/~55.5%	~41.8%/~53.3%
Latency	Observed as same in DSR application benchmarking		

Recommendation: Virtual network interrupt coalescing: Enabled; SplitRxMode: Enabled.

Power Settings

VMware ESXi allows assignment of power management profiles. These profiles allow the user to configure the host to save power while balancing performance. The power management profiles use the host's processor ACPI power setting. Many host manufacturer's bios overrides the ESXi settings.

Table 4: Power Management Profiles

ESXi Power Mode	High Performance	Balanced Performance
System.CPU UtilPct (Avg/Max)	~40%/~60%	~38%/~55%
Dsr.Cpu (Avg/Max)	~38%/~48%	~36%/~44%
Used %/Run %/System %	~472/~388/~49%	~462/~376/~49%
Wait %/Idle %	~407%/~1013	~419%/~1023

The data in the table above is collected from a DA MP, but similar trends are observed on the other DSR virtual server types. A small but significant difference was observed between balanced and high performance power settings. However, the data did not indicate a large enough deviation to vary from the hardware vendor's guidelines. DSR benchmark testing was performed with ESXi Power Mode set to Balanced Performance.

Recommendation: Refer to host hardware vendor power management guidelines for virtualization.

Hardware Assisted Virtualization

VMware ESXi automatically determines if a virtual machine can use hardware support for virtualization based on processor type. Several settings were selected for assessing performance:

- A. Automatic
- B. Use software for instruction set and MMU virtualization.
- C. Use Intel® VT-x/AMD-V™ for instruction set virtualization and software for MMU virtualization
- D. Use Intel® VT-x/AMD-V™ for instruction set virtualization and Intel® EPT/AMD RVI for MMU virtualization

Also testing with "Node Interleaving" setting Enabled (that is, NUMA disabled), with no noticeable changes in performance.

Table 5: Virtualization Performance by Processor

MMU Virtualization Setting	A.	B.	C.	D.
System CPU UtilPct (Max/Avg)	57.5/38%	71.5/43%	71.5/43%	53/38%
Dsr.Cpu (Max/Avg)	43.5/36.3%	50/38.6%	50/38.5%	43/36.3%

The data in the table above is provided from a DA MP. Trends for other servers are similar. The automatic (default) settings provide performance better than options B and C above, and fairly equivalent to option D.

Recommendation: Refer to host hardware vendor guidelines for virtualization. Defaults recommended.

Virtual Machine Storage Configuration

Storage Type Adapter

Testing was performed with the default "LSI Logic Parallel" option. No testing was performed against recent virtual SCSI adapters (LSI Logic SAS and VMware para-virtualized (PVSCSI.) At the time of testing the default was considered as the most stable and compatible.

Recommendation: Default "LSI Logic Parallel"

Disk Provisioning

The following disk provisioning options are available when deploying a virtual machine:

- **Thick Provision Lazy Zeroed:** All space needed for the VM is allocated during creation. Data on the host disk is zeroed out at a later time on first write from the virtual machine.
- **Thick Provision Eager Zeroed:** All space needed for the VM is allocated during creation. The data on the host disk is zeroed out during creation. Time to deploy the virtual machine is increased with this option. This option supports fault tolerant features provided by the infrastructure.
- **Thin Provision:** This option uses only the amount needed by the virtual machine disk. The image grows as needed until the allocated capacity is reached.

With the high availability of the DSR, storage should be allocated at the time the VM is created, so thin provisioned is not recommended. When instantiating a fairly typical DSR VM with 60G of storage, the lazy zeroed disk was created almost instantaneously. Whereas the eager zeroed disk took about 7 minutes to initialize. Lazy zeroed is recommended.

Recommendation: Thick Provisioned Lazy Zeroed.

Large Memory Pages

VMware ESXi Large-page support enables server applications to establish large-page memory regions. The use of large pages can potentially increase TLB access efficiency and thus improve program performance. By default Large page support is enabled on VMware ESXi Server although the full benefit of large pages comes only when guest OS and applications use them as well. By default large page support is not enabled in the DSR product.

The following settings were evaluated:

- Default settings (such as, Large memory pages support enabled on host and large pages configured as 0 on guest).
- Large memory pages support enabled on host and 1024 large pages configured on guest.
- Large memory pages support disabled on host.

Recommendation: Default settings. No visible advantage was observed when comparing iterative memory stats as observed through `/proc/meminfo`. No visible advantage could be observed in using large pages.

Benchmark Testing

The way the testing was performed and the benchmark test set-up is the same for each benchmark infrastructure. Each section below describes the common set-up and procedures used to benchmark, and then the specific results for the benchmarks are provided for each benchmark infrastructure. In general the benchmarking results for VMware/ESXi vs. Openstack/KVM are close enough that only one set of numbers are shown.

DA MP Relay Benchmark

Overview

This benchmarking case illustrates conditions for an overload of a DSR DA MP. Simulator message rate is increased until the DA-MP Overload mechanisms are triggered causing messages to be discarded.

Topology

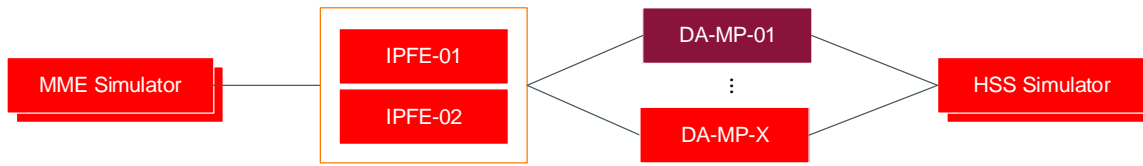

Figure 1: DA-MP Testing Topology

Figure 1 illustrates the logical topology used for this testing. Diameter traffic is generated by an MME simulator and sent to an HSS simulator. The traffic is ramped up in increments until congestion is seen on the DA-MPs indicating that the maximum normal traffic handling capacity has been reached for the current message flow.

The dsr.cpu utilization can be increased from dsr.cpu 53% to higher levels by means of configuration changes with DOC/CL1/CL2 discards set to 0 and multi queuing enabled on all hosts. With this configuration, it must be noted that all the discards will be at one step CL3 for all incoming and outgoing messages. The Default CPU threshold configuration shall remain the same which is DOC: 54% CPU ; CL1: 60% CPU ; CL2: 66% CPU.

The Relay traffic with the above configuration changes is measured at 36K MPS at 66% dsr.cpu for a DA-MP profile as defined in Appendix A. DSR VM Configuration. The hyper threading was enabled

Message Flow

Figure 2 illustrates the Message sequence for this benchmark case.

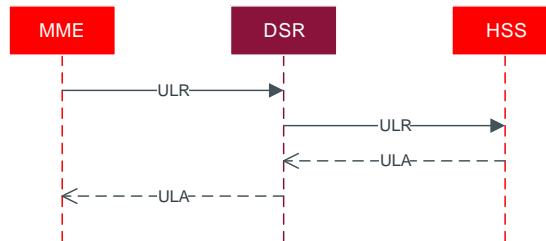

Figure 2: DA-MP Message Sequence

Table 6: DA-MP Test Set Up

Messages		Traffic Details	
Message	Distribution	Detail	Distribution
ULR, ULA	100%	Average Message Size	2.2K
		Cross DSR Routing	75% or higher

Large VM profile for DA-MP

A new VM profile is introduced for DA-MP, the intention of having the large profile is to get more MPS per DA-MP VM. The DSR Nodal MPS limits, IPFE bandwidth limits, number of DA-MP per DSR site, number of total connection limits remains same with this configuration as well.

- The large DA-MP VM resource profile is 18 vCPU, 24GB RAM, 70 GB Disk. We call this Large DA-MP profile.
- New DA-MP profiles configurations are introduced, VM:35K_MPS.

Benchmarking Setup:

- The benchmarking setup involved 2 Large DA-MP each in different CPU NUMA sockets, on the underlying hardware achieving 35K MPS of RBAR traffic on each of the Large DA-MP resource profile at ~54% dsr.cpu.
- A Large DA-MP shall not span across NUMA.
- Underlying hardware used: Gen10 Architecture: x86_64 with Hyper-threading enabled.
CPU op-mode(s): 32-bit, 64-bit.

Indicative Alarms/Events

During benchmark testing the following alarms/events were observed as it crossed into congestion.

Table 7: DA-MP Alarms/Events

Number	Severity	Server	Name	Description
5005	Minor	IPFE	IPFE Backend in Stasis	A backend server not accepting new connections but continuing to process existing connections
22200	Major	DA-MP	Communication Agent Routed Service Congested	The Diameter process is approaching or exceeding its engineered traffic handling capacity
22215	Major	DA-MP	Ingress Message Discarded: DA MP Overload Control	Ingress message discarded due to DA MP (danger of) CPU congestion.

DA-MP Indicators for Capacity Expansion

The following DSR system measurements, KPIs and events can be used to monitor the performance of the DA-MP in a field deployment, or to drive the orchestration of DA-MP expansion.

DA-MP Utilization

In this section, only the key recommended metrics for planning expansions of the DA-MP are discussed. There are many more measurements available on the DA-MP, and these can be found in [[2]].

The key metrics for managing the DA-MP are:

Table 8: DA-MP Utilization Metrics

Measurement ID	Name	Group	Scope	Description	Recommended Usage	
					Condition	Actions
10204	MpCPUAvg	MP Performance	Server Group	Average percent Diameter Process CPU utilization (0-100%) on a MP server	When running in normal operation with a mate in normal operation, and this measurement exceeds 30% of the rated maximum capacity, OR Exceeds 60% of the rated capacity when running without an active mate.	If additional growth in the system is anticipated, then consider adding an additional DA-MP. It is possible that the traffic mix is different than originally dimensioned (for example, 40% IPSEC instead of the originally dimensioning 5%). In these cases, re-assess the dimensioning with the actual traffic/application mix and add additional DA-MPs as needed.
10133	RxMsgSizeAvg	Diameter Performance	Server Group	The average ingress message size in Diameter payload octets	Average message size > 2000 bytes	DA-MP dimensioning assumes 2K average message size. This information is used to dimension IPFEs and DIH/IDIH. No action required if there are no alarms associated with the PDU message pool (available memory for messages). If PDU message pool is exhausting, contact Oracle.
31056	RAM_UtilPct_Average	System	System	The average committed RAM usage as a percentage of the total physical RAM	If the average Ram utilization exceeds 80% utilization	Contact Oracle
31052	CPU_UtilPct_Average	System	System	The average CPU usage from 0 to 100% (100% indicates that all cores are completely busy)	When running in normal operation with a mate in normal operation, and this measurements exceeds 30% of the rated maximum capacity, OR Exceeds 60% of the rated capacity when running without an active mate.	If additional growth in the system is anticipated, then consider adding an additional DA MP. It's possible that the traffic mix is different than originally dimensioned (for example, 40% IPSEC instead of the originally dimensioning 5%). In these cases, re-assess the dimensioning with the actual traffic and application mix and add additional DA-MPs VMs as needed.

Measuring DA-MP Connection Utilization

In this section, only the key recommended metrics for planning expansions of the DA-MP connections are discussed. There are many more measurements available on the DA-MP connections, and these can be found in [[2]].

The key metrics for managing the DA-MP connections are:

Table 9: DA-MP Connection Metrics

Measurement ID	Name	Group	Scope	Description	Recommended Usage	
					Condition	Actions
10500	RxConnAvgMPS	Connection Performance	Connection	Average Ingress Message Rate (messages per second) utilization on a connection	Minor alarm is set by default at 50%, major at 80%. Ingress message rate per connection is customer configurable with a max per connection of 10,000	Configure additional connections

Suggested Resolution

If congestion alarms shown in Table 7: DA-MP Alarms/Events, then add additional DA-MPs to avoid CPU congestion. However, if the connection alarm shown in Table 9: DA-MP Connection Metrics is seen, then adding additional connections for that peer helps distribute the load and alleviates the connection alarm.

In general, the growth mechanism for DA MPs is via horizontal scaling. That is by adding additional DA MPs. The current maximum number of the DA MPs per DSR signaling NE is 32.

810K MPS Support

Overview

810K MPS traffic is supported on 40K_MPS_FABR profile. The DSR Nodal MPS limits, IPFE bandwidth limits, number of DA-MP per DSR site, number of total connection limits remains same with this configuration as well.

- The 40K_MPS_FABR DA-MP VM resource profile is 24 vCPU, 24GB RAM, 70 GB Disk.
- New DA-MP profile configurations are introduced, VM:40K_MPS_FABR.

Benchmarking Setup:

- The benchmarking setup involved 32 DA-MP, with following call mix
 - 66% was FABR traffic
 - 33% was DSR relay traffic.
- A DA-MP shall not span across NUMA.
- Average CPU
- Underlying hardware used: X5-2 Architecture: x86_64 with Hyper-threading enabled.
CPU op-mode(s): 32-bit, 64-bit.

Following is other configuration used for this benchmarking

Configuration Object	Configured Quantity
Number of IPFE	4
Number of DAMP in TSA group	16

Number of Initiator Connections	2400
Number of Responder Connections	6240
Average Message Size	1500

Full Address Based Resolution (FABR) Capacity

Overview

The FABR application adds a Database Processor (DP) server is to perform database lookups with a user defined key (IMSI, MSISDN, or Account ID and MSISDN or IMSI.) If the key is contained in the database, the DP returns the realm and FQDN associated with that key. The returned realm and FQDN can be used by the DSR Routing layer to route the connection to the desired endpoint. Since there is additional work done on the DA-MP to query the DP, running the FABR application has an impact on the DA-MP performance. This section contains the performance of the DA-MP while running FABR as well as benchmark measurements on the DP itself.

Topology

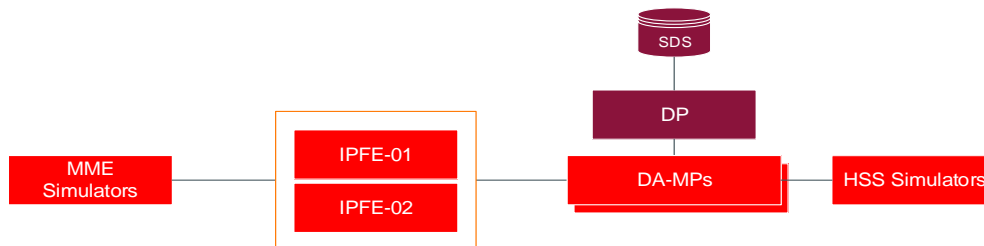

Figure 3: SDS DP Testing Topology

SDS DB Details

The SDS database was first populated with subscribers. This population simulates real-world scenarios likely encountered in a production environment and ensure the database is of substantial size to be queried against.

- SDS DB Size: 300 Million Routing Entities (150 M MSISDNs/150 M IMSIs)
- AVP Decoded: User-Name for IMSI

New SDS profile (Large) is introduced to enhance the capacity of SDS FABR database to 1 Billion Routing Entities. The Large profile is defined in Appendix A. DSR VM Configurations based on the below 1 Billion Entry configuration:

- 260 Million Subscribers having 2 IMSI, 1 MSISDN = 780 Million Routing entities. IMSI = 15 bytes, MSISDB= 11 bytes.
- 220 Million IOT records, of 27 bytes each.
- Destinations: 300 Entries.
 - One Destination per Routing Entity is configured.
 - Longest FQDN configured: 32 characters
 - Longest Realm configured: 13 characters

Message Flow

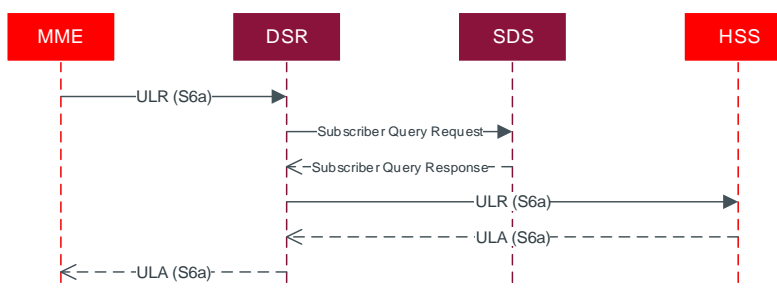

Figure 4: SDS DP Message Sequence

Table 10: SDS DP Message Details

Messages		Traffic Details	
Message	Distribution	Detail	Distribution
ULR, ULA	100%	Average Message Size	2.2K
		Cross DSR Routing	75% or higher

DP Indicators for Capacity Expansion

Table 11: SDS DP Alarms/Events

Number	Severity	Server	Name	Description
19900	Minor	sdsDP	Process CPU Utilization	The Process, which is responsible for handling all traffic, is approaching or exceeding its engineered traffic handling capacity.
19822	Major	DA-MP	Communication Agent Routed Service Congested	Communication Agent Routed Service Congested.
19825	Major/Critical	DA-MP	Communication Agent Transaction Failure Rate	The number of failed transactions during the sampling period has exceeded configured thresholds.
19826	Major	sdsDP	Communication Agent Connection Congested	Communication Agent Connection Congested.
19831	Info	DA-MP	Communication Agent Service Operational State Changed	Communication Agent Service Operational State Changed, Instance DPService.
19816	Info	DA-MP	Communication Agent Connection state Changed	Configuration Mode = Configured, Admin State = Enabled, Connect Mode = Server, Operational State = Degraded, Congestion Level = 1, Overload Level = 1, Transport Congestion Level = 0.

Measuring DP Utilization

In this section, only the key recommended metrics for managing the performance of the DP are discussed. There are many more measurements available on the DP, and these can be found in [[2]].

There are two key components of the subscriber database within a DSR Signaling node: the Database Processors (DPs), and OAM component which runs on the System OAM VMs. The key metrics for managing the DPs are:

Table 12: SDS DP Utilization Metrics

Measurement ID	Name	Group	Scope	Description	Recommended Usage	
					Condition	Actions
4170	DpQueriesReceived	DP	System (per DP)	The total number of queries received per second	When running in normal operation with a mate in normal operation, and this measurement exceeds 30% of the benchmarked maximum capacity, OR Exceeds 60% of the benchmarked capacity when running without an active mate.	The operator should determine if additional growth in the number traffic requiring subscriber database look-ups is continuing to grow. If so, an estimate of the additional rate of database lookups should be calculated and additional DPs should be planned for.
31056	RAM_UtilPct_Average	System	System (per DP)	The average committed RAM usage as a percentage of the total physical RAM	If the average Ram utilization exceeds 80% utilization	Contact Oracle
31052	CPU_UtilPct_Average	System	System (per DP)	The average CPU usage from 0 to 100% (100% indicates that all cores are completely busy)	When running in normal operation with a mate in normal operation, and this measurements exceeds 30% of the rated maximum capacity, OR Exceeds 60% of the benchmarked capacity when running without an active mate.	Oracle considers this measurement of lesser importance to the DpQueriesReceived. However, this measurement in conjunction with DpQueriesReceived can be used to indicate the need to add additional DPs.

While memory is a consideration for the DPs, the SDS provides the centralized provisioning for the entire DSR network.

The OAM application related to the DPs (DP SOAM) runs at each DSR Signaling NE requiring the Full Address Resolution feature. Currently these are fixed sized VMs with no horizontal or vertical scaling recommended as no need for scaling these VMs has been observed. The following two metrics should be monitored,

Table 13: DP SOAM Metrics

Measurement ID	Name	Group	Scope	Description	Recommended Usage	
					Condition	Actions
31056	RAM_UtilPct_Average	System	System (per DP SOAM)	The average committed RAM usage as a percentage of the total physical RAM	If the average Ram utilization exceeds 80% utilization	Contact Oracle
31052	CPU_UtilPct_Average	System	System (per DP SOAM)	The average CPU usage from 0 to 100% (100% indicates that all cores are completely busy)	If the average CPU utilization exceeds 80% utilization	Contact Oracle

Suggested Resolution

The growth mechanism for DPs is via horizontal scaling by adding additional DPs. The current maximum number of the DPs per DSR signaling NE is 10. This amount of scaling currently well exceeds capacities of the DA MPs driving queries to the DPs.

vSTP MP

Overview

The vSTP-MP server type is a virtualized STP that supports M2PA, M3UA, and TDM. It can be deployed either with other DSR functionality as a combined DSR/vSTP, or as a standalone virtualized STP without any DSR functionality.

The vSTP MP requires 8 GB of RAM. Up to 32 vSTP MPs can be configured, with a capacity of 20k MPS per vSTP MP giving a total MPS of 600k. For EIR application, the capacity of 5k MPS per vSTP MP giving a total MPS of 160k.

vSTP MP Benchmarking

The following table describes the feature-wise vSTP MP benchmarking:

Table 14: Feature-wise vSTP MP Benchmarking

vSTP Feature	Max Traffic combination (TPS supported per MP)
SFAPP+MNP + GTT	2K (MNP + SFAPP) + 6K GTT
SFAPP + MNP + GFLEX + GTT	2K (MNP + SFAPP) + 1K GFLEX + 4K GTT
TIF + GTT	4K MNP+ 6K GTT
vMNP + GTT	5K MNP+ 8K GTT
GFLEX + GTT	5K MNP+ 8K GTT
INPQ + GTT	5K MNP+ 8K GTT
GTT + MTP Routing with MTP screening (M2PA & M3UA)	16K MPS
GTT + MTP Routing	20K MPS
vEIR	5K

Note:

- Default timer values are supported when vSTP is configured to operate at 10K MPS per MP.
- When vSTP is configured to operate at 20K MPS, then the **t1Timer** to **t5Timer** values has to be updated. Refer to MMI API Specification for the updated timer values.

vSTP MP Indicators for Capacity Expansion

Utilization

In this section, only the key recommended metrics for planning expansions of the VSTP-MP are discussed. There are many more measurements available on the VSTP-MP, and these can be found in [[2]].

The key metrics for managing the VSTP-MP are:

Table 15: VSTP-MP Utilization Metrics

Measurement ID	Name	Group	Scope	Description	Recommended Usage	
					Condition	Actions
21150	VstpANSIPDUUtilAvg	VSTP Server Resource	Site	The average SS7 ANSI PDU Buffer Pool utilization (0-100%) measured during the collection interval	A PDU is allocated to each message that arrives at a vSTP and is de-allocated when message processing completes. This measurement is useful for evaluating whether persistent network problems exist. In general, PDU buffers are engineered to match the processing capacity of the vSTP. If network problems exist, egress messages from the vSTP are delayed, then PDUs/messages also sit in internal SS7 queues.	If both the peak and average measurements for multiple vSTPs within a Network Element are consistently near the recommended maximum engineered capacity of a vSTP when the ingress Message Rate and/or SS7 Process CPU Utilization measurement are below the recommended engineered capacity of a vSTP, then a network (IP or SS7) problem may exist. Looking at these measurements on a time of day basis may provide additional insight into potential network problems.
21151	VstpITUPDUUtilAvg	VSTP Server Resource	Site	The average SS7 ITU PDU Buffer Pool utilization (0-100%) measured during the collection interval		
31056	RAM_UtilPct_Average	System (vSTP MP)	System	The average committed RAM usage as a percentage of the total physical RAM	If the average Ram utilization exceeds 80% utilization	Contact Oracle.
31052	CPU_UtilPct_Average	System (vSTP MP)	System	The average CPU usage from 0 to 100% (100% indicates that all cores are completely busy)	When running in normal operation with a mate in normal operation, and this measurements exceeds 30% of the rated maximum capacity, OR Exceeds 60% of the rated capacity when running without an active mate.	If additional growth in the system is anticipated, then consider adding an additional vSTP MP. It's possible that the traffic mix is different than originally dimensioned. In these cases, re-assess the dimensioning with the actual traffic and application mix and add additional VSTP-MPs VMs as needed.

Suggested Resolution

In general, the growth mechanism for vSTP MPs is via horizontal scaling, that is by adding additional vSTP MPs. The current maximum number of vSTP MPs per DSR signaling NE is 32.

Policy DRA (PDRA) Benchmarking

Overview

The Policy DRA (PDRA) application adds two additional database components, the SBR(session) (SBR-s) and the SBR(binding) (SBR-b). The DA-MP performance was also measured since the PDRA application puts a different load on the DA-MP than either running Relay or FABR traffic. There are two sizing metrics when determining how many SBR-s or SBR-g server groups (for example, horizontal scaling units) are required. The first is the MPS traffic rate seen at the DA-MPs in Figure 5. This is the metric that is benchmarked in this document. The second factor is the number of bindings (SBR-b) or

sessions (SBR-s) that can be supported. This session/binding capacity is set primarily by the memory sizing of the VM, and is fixed at a maximum of 16 million per SBR from the DSR 8.3 release. The number of bindings and sessions required for a given network are customer dependent. But a good starting place for engineering is to assume:

- The number of bindings is equal to the number of subscribers supported by the PCRFs.
- The number of sessions is equal to number of subscribers times the number of IPCAN sessions required on average for each subscriber. For instance, a subscriber might have one IPCAN session for LTE, and one for VoLTE. Note the number of sessions is always be equal to or greater than the number of bindings.

Topology

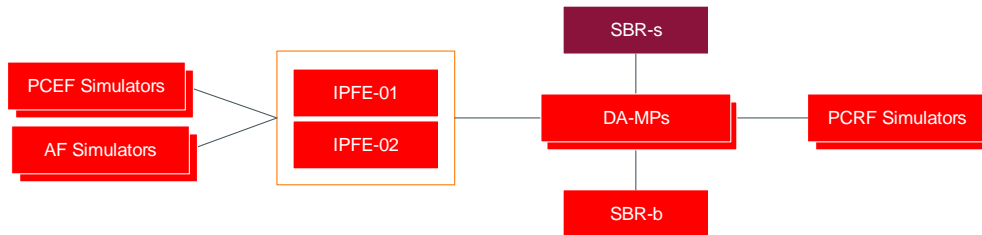

Figure 5: SBR Testing Topology

Message Flow

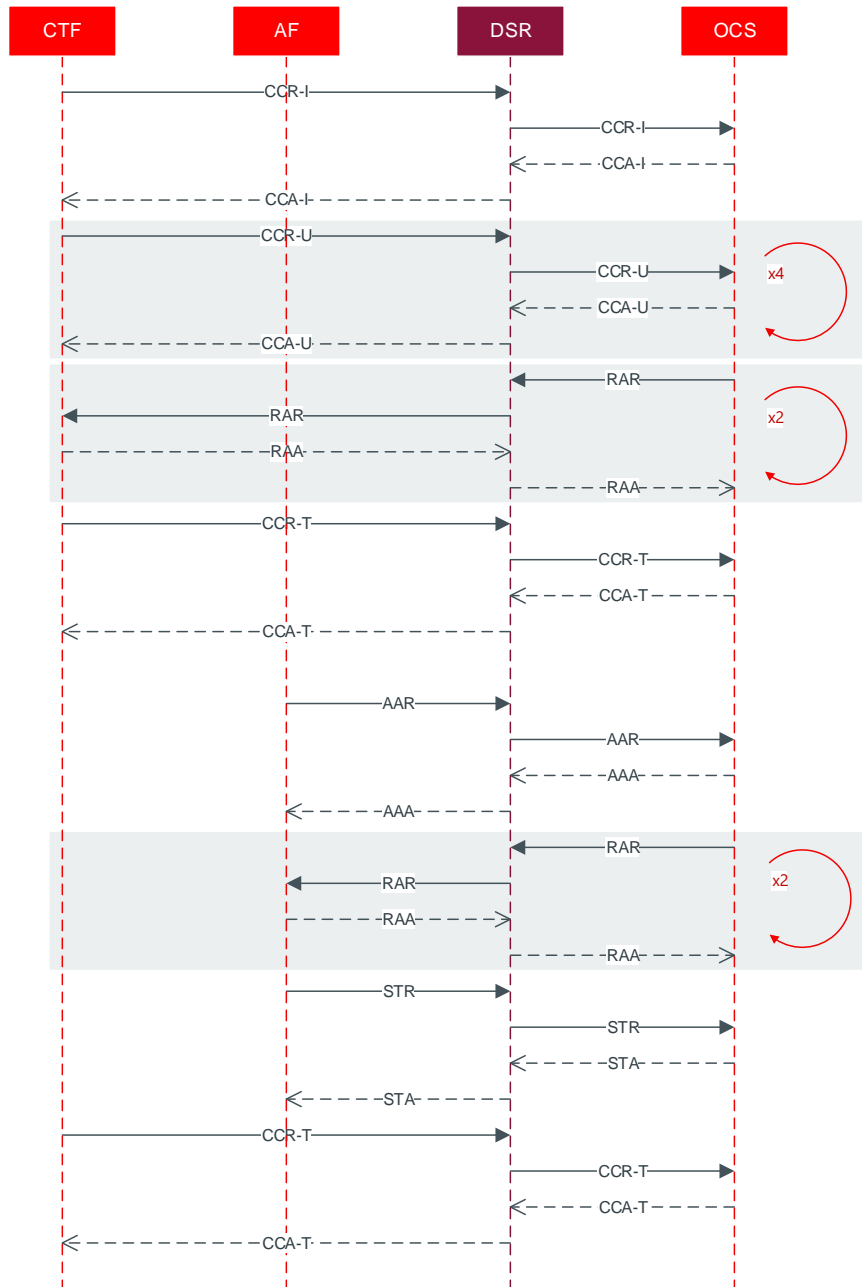

Figure 6: PDRA Message Sequence

Table 16 shows the call model used for the testing. The message distribution is Oracle's baseline benchmarking, and may differ significantly from customer distributions based on factors such as the penetration of LTE support vs. VoLTE support. The Traffic Details shows the configured PDRA options. For more details on these options please see [[4]].

Table 16: PDRA Test Call Model

Messages		Traffic Details	
Message	Distribution	Message	Distribution
CCR-I, CCA-I	8.5%	Gx w/ IPv6 Alternate Key	100%
CCR-U, CCA-U	25.5%	Gx w/ IPv4 Alternate Key	0%
CCR-T, CCA-T	8.5%	Gx with MSISDN Alternative Key	100%
Gx RAR, RAA	25.5%	Gx Topology Hiding	0%
AAR, AAA Initial	12.8%	Rx Topology Hiding	0%
STR, STA	12.8%		
Rx RAR, RAA	6.4%		

Indicative Alarms/Events

Table 17: SBR (b) Alarms/Events

Number	Severity	Server	Name	Description
19825	Minor/Major/Critical	DA-MP	Communication Agent Transaction Failure Rate	The number of failed transactions during the sampling period has exceeded configured thresholds.
19826	Major	DA-MP, SBR(s)	Communication Agent Connection Congested	Communication Agent Connection Congested
19846	Major	DA-MP, SBR(s)	Communication Agent Resource Degraded	Communication Agent Resource Degraded
22051	Critical	SOAM	Peer Unavailable	Unable to access the Diameter Peer because all of the diameter connections are Down.
22101	Major	SOAM	Connection Unavailable	Connection is unavailable for Diameter Request/Answer exchange with peer.
22715	Minor	SBR(s)	SBR Audit Suspended	SBR audit is suspended due to congestion.
22725	Minor/Major	SBR(s)	SBR Server In Congestion	SBR server operating in congestion.
22732	Minor/Major	SBR(s)	SBR Process CPU Utilization Threshold Exceeded	SBR process CPU utilization threshold has been exceeded.

Measurements

Key metrics for managing the Session SBR(b) VMs are:

Table 18: Session SBR (b) VMs Metrics

Measurement ID	Name	Group	Scope	Description	Recommended Usage	
					Condition	Actions
31052	CPU_UtilPct_Average	System	System (SBR)	The average CPU usage from 0 to 100% (100% indicates that all cores are completely busy).	When this measurement exceeds 60% utilization	Contact Oracle
31056	RAM_UtilPct_Average	System	SBR	The average committed RAM usage as a percentage of the total physical RAM.	If the average Ram utilization exceeds 80% utilization	Contact Oracle
11372	SbrPolicySessionRecsAvg	SBR Session Performance	Server Group	The number of policy sessions in progress	If PDRA function is enabled and OC-DRA is not enabled and average exceeds benchmarked capacity. If both PDRA and OC-DRA are enabled this average must be combined with the SbrOcSessionRecsAvg and the combined average exceeds benchmarked capacity.	Contact Oracle
11441	SbrOcSessionRecsAvg	SBR Session Performance	Server Group	The number of online Charging sessions in progress	If OC-DRA function is enabled and PDRA is not enabled and average exceeds benchmarked capacity. If both PDRA and OC-DRA are enabled this average must be combined with the SbrPolicySessionRecsAvg and the combined average exceeds benchmarked capacity.	Contact Oracle

Key metrics for managing the Binding SBR(b) servers are:

Table 19: Binding SBR (b) Server Metrics

Measurement ID	Name	Group	Scope	Description	Recommended Usage	
					Condition	Actions
31052	CPU_UtilPct_Average	System	System (blade)	The average CPU usage from 0 to 100% (100% indicates that all cores are completely busy)	When this measurement exceeds 60% occupancy.	Contact Oracle
31056	RAM_UtilPct_Average	System	Blade	The average committed RAM usage as a percentage of the total physical RAM	If the average Ram utilization exceeds 80% utilization	Contact Oracle
11374	SbrPolicyBindingRecsAvg	SBR Binding Performance	Server Group	Average number of active SBR Policy bindings	When this average exceeds benchmarked capacity.	Contact Oracle

Suggested Resolution

If either additional Bindings or MPS capacity is required is required then additional Server Groups may be added to an existing SBR(b) using the SBR reconfiguration feature. There can be up to 8 Server Groups in the SBR(b).

Diameter Security Application (DSA) Benchmarking

Diameter Security application (DSA) applies countermeasures for ingress messages received from external foreign network and for egress messages sent to external foreign network. Different countermeasure profiles can be created for different IPX or roaming partners by enabling/disabling countermeasures individually for different IPX provider or roaming partner Diameter Peers. DSA application is enabled on DA-MP and it uses vUDR to store context information.

Topology

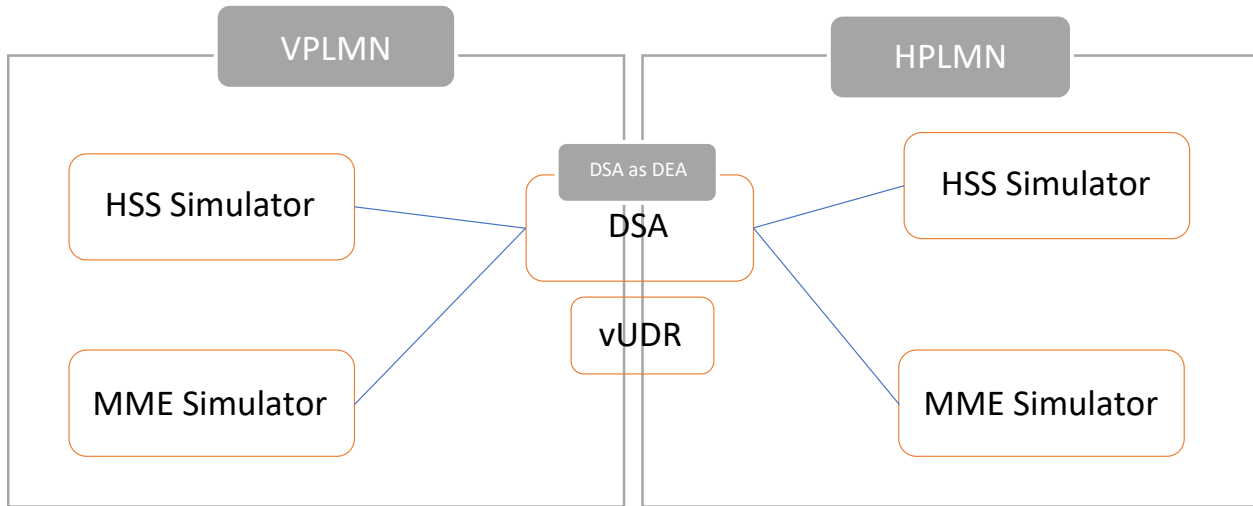

Figure 7: DSA Testing Topology

The following stateful and stateless counter measure application configuration and the modes of operations used in benchmarking tests.

Table 20: Stateful and Stateless Counter Measures

Application Configuration Data		General Options Settings	
Table Name	Count of Configured Entries	Options	Values
AppCmdCst_Config	2	Opcodes Accounting	Disabled
AppldWL_Config	1	Max. UDR Queries per Message	10
AVPInstChk_Config	59	Max. Size of Application State	4800
Foreign_WL_Peers_Cfg_Sets	20	Logging of Vulnerable Messages	Enabled
MCC_MNC_List	111		
MsgRateMon_Config	8		
Realm_List	112		
Security_Countermeasure_Config	15		
SpecAVPScr_Config	58	Application Threads	
System_Config_Options	1	Request	6
TimeDistChk_Config	2000	Answer	4
TTL_Config	5	SbrEvent	4
VplmnORCst_Config	1	AsyncEvent	2
TimeDistChk_Country_Config	225		
TimeDistChk_Exception_List	164		
TimeDistChk_Continent_Config	15		
VplmnORCst_Config	1		
RealmIMSI_Cst_Config	20		
Exception_Rule_Config	15		
All Exception Types Table <ul style="list-style-type: none"> ▪ IMSI_Exception_Config ▪ MCC_MNC_Exception_Config ▪ Origin_Host_Exception_Config ▪ Realm_Exception_Config ▪ VPLMN_ID_Exception_Config 	100		

The following is the MPS, CPU, CM description for a 10K MPS DA-MP VM profile.

Table 21: 10K MPS DA-MP VM Profile with Regular UDR profile

Counter Measure (CM)	MPS (K)	CPU	Operating Mode
All Stateful	8.0	49.1	Detection only
Previous_Location_Check	9.8	47.6	Detection only
Time_Distance_Check	9.8	46.7	Detection only
Source_Host_Validation_Hss	9.6	48.4	Detection only
Source_Host_Validation_Mme	10	47.2	Detection only

Table 22: 30K MPS DA-MP VM Profile with Regular UDR profile

Counter Measure (CM)	MPS (K)	CPU	Operating Mode
All Stateful	8.0	48.7	Detection only
Previous_Location_Check	9.2	44.9	Detection only
Time_Distance_Check	9.8	46.4	Detection only
Source_Host_Validation_Hss	9.6	46.8	Detection only
Source_Host_Validation_Mme	10	45.1	Detection only

Some of the operators don't have higher MPS requirement. Following various UDR profiles and MP profiles combinations are used for benchmarking. These lower UDR profile will help operators to save on resources.

Table 23: UDR VM Profile

UDR Profile	vCPU	RAM in GB	Disk in GB
Small	4	16	220
Medium	8	32	400
Large	14	64	400
Regular	28	128	800

Table 24: DAMP combination with UDR Profile

Counter Measure (CM)	DAMP Profile	vUDR Profile	MPS (K)	CPU	Operating Mode
All Stateful + All Stateless	30K_MPS	Small	2.03	17.5	Detection only
All Stateful	30K_MPS	Medium	4.06	30.5	Detection only
All Stateful	30K_MPS	Large	7.02	45.5	Detection only
All Stateful + All Stateless	30K_MPS	Large	5.25	41.5	Detection only

Service Capability Exposure Function (SCEF) Benchmarking

SCEF/MTC-IWF functionality at DSR adds two functional components.

- The Core SCEF/MTC-IWF component which provides interfaces towards the HSS, MME/SGSN, PCRF. This functionality is part of DA-MP where SCEF/MTC-IWF application is implemented.
- The API gateway (OCSG) component which comprises of API admin, API App Server, API gateway DB which provides exposure to SCS/AS on the HTTP interface.

Topology

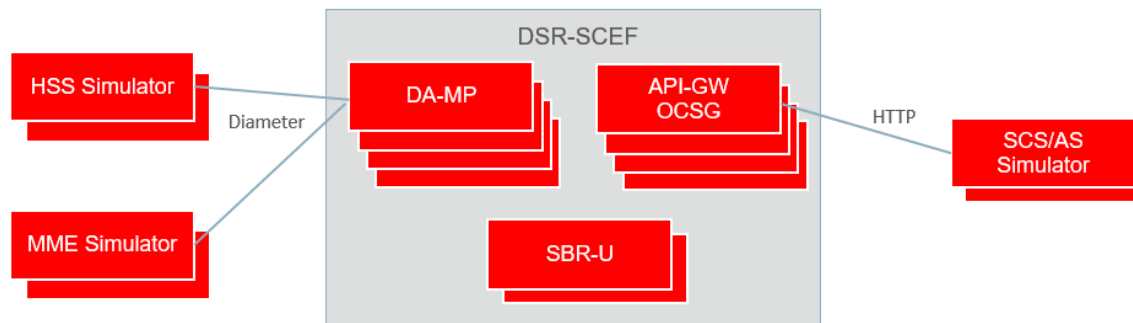

Figure 8: SCEF Testing Topology

There are three factors that determine the sizing of SCEF. The Performance of DA-MP with SCEF, API gateway (OCSG) and the SBR universal (u). SBR- u is used by SCEF to store IoT Device context information related to MTC procedures. In general, SBR-u capacity computation is based on number of devices and number of MTC procedures planned to be deployed by MNO.

$$\text{Number of U-SBR Sessions} = \text{Number of IoT Devices} \times \text{Number of MTC procedures planned for deployment.}$$

Each of supported MTC procedures adds a separate record into U-SBR database.

Number of MPs and U-SBR server group's required must be decided based on MNO's traffic pattern and IoT Device capacity. The capacity numbers are mentioned in section Summary of Benchmark Data Recommendations.

The benchmarking involved running a call mix on a 5K MPS profile, of equal proportions for Non IP Data Delivery, Monitoring and Device Trigger on a 4 DA-MP, 4 OCSG (API gateway) system to make sure all memory, CPU, measurements and metrics stay in the acceptable range for MP's.

Key metrics for managing the SCEF DA-MP servers are:

Table 25: SCEF DA-MP Server Metrics

Measurement ID	Name	Group	Scope	Description	Recommended Usage	
					Condition	Actions
19300	DxNiddMsgRateMetric	SCEF	System (blade)	The number of messages processed every second by the NIDD feature of SCEF application	If the numbers exceed the benchmark ed capacity	Contact Oracle
19400	DxDevTriggMsgRateMetric	SCEF	System (blade)	The number of messages processed every second by the Device Trigger feature of SCEF application		

Measurement ID	Name	Group	Scope	Description	Recommended Usage	
					Condition	Actions
19350	DxMonMsgRateMetric	SCEF	System (blade)	The number of messages processed every second by the Monitoring feature of SCEF application		

Suggested Resolution

The growth mechanism for DA MPs, OCSG App Server is via horizontal scaling. That is by adding additional DA MPs. The current maximum number of the DA MPs, OCSG App server per DSR signaling NE is 32. If SCEF context information or MPS capacity is required then additional Server Groups may be added to an existing SBR(u) using the SBR reconfiguration feature. There can be up to 64 Server Groups in the SBR(u).

Equipment Identity Register (EIR)

The EIR application is enabled on the DA-MP with interface towards the MME/GGSN and STP MP provides the SS7 Interface towards the MSC. An internal interface is provided as a query interface to the UDR-NO.

The UDR NO provides the functionality of the Equipment Identity Register (EIR) database to the DSR. The database stores white, gray, and black lists of IMEI numbers. It can support up to 100 Million subscribers, 10 Million IMEI range/TAC with 1 IMEI supporting up to 10 IMSIs.

Topology

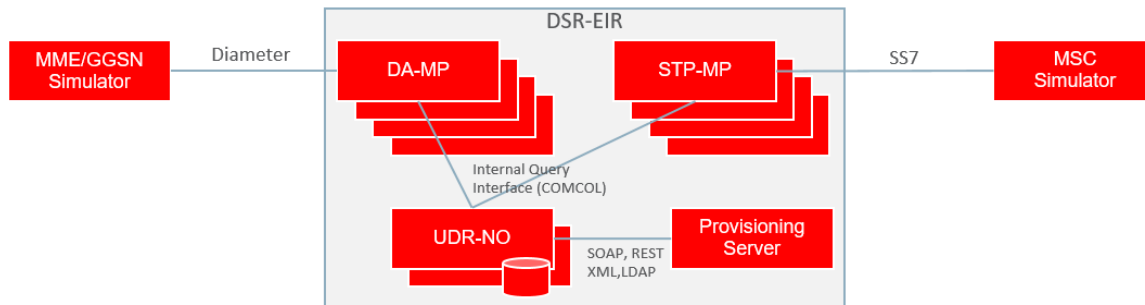

Figure 9: EIR Testing Topology

Benchmarking was done for 5K EIR traffic using vSTP MP profile and DAMP profile, for vSTP EIR and Diameter EIR respectively with 10 million subscribers configured and a max 500 TPS subscriber provisioning traffic at UDR-NO. Each subscriber is configured up to 10 IMSIs. It was observed that the Average response time of ~7ms UDR-NO Query processing time.

NOAM

Overview

Specific benchmark data for the DSR NOAM is not provided in this release as the DSR Cloud deployable footprint is modest and system testing of the DSR indicates that NOAM growth is not currently needed.

Indicative Alarms/Events

The DSR Network OAM is potentially a RAM intensive function. The Network OAM is designed not to exceed the available memory; however RAM is the most likely resource constraint.

Measurements

Measuring Network OAM Utilization

In this section, only the key recommended metrics for managing the performance of the Network OAM are discussed. There are many more measurements available, and these can be found in [[2]].

The key metric for managing the Network OAM Servers are:

Table 26: Network OAM Metrics

Measurement ID	Name	Group	Scope	Description	Recommended Usage	
					Condition	Actions
31056	RAM_UtilPct_Average	System	System (server)	The average committed RAM usage as a percentage of the total physical RAM	If the average Ram utilization exceeds 80% utilization	Contact Oracle

Suggested Resolution

The NOAM can be vertically scaled; however this action is not anticipated to be necessary with the DSR cloud deployable footprint. Please contact Oracle support for additional guidance as needed.

SOAM

Overview

Specific benchmark data for the DSR SOAM is not provided in this release as the DSR Cloud deployable footprint is modest and system testing of the DSR indicates that SOAM growth is not currently needed.

Indicative Alarms/Events

A key metric for managing the System OAM VM is:

Table 27: System OAM Metrics

Measurement ID	Name	Group	Scope	Description	Recommended Usage	
					Condition	Actions
31056	RAM_UtilPct_Average	System	VM	The average committed RAM usage as a percentage of the total physical RAM	If the average Ram utilization exceeds 80% utilization	Contact Oracle

Suggested Resolution

The DSR SOAM can be vertically scaled, the criteria for vertically scaling to a SOAM large profile (refer DSR VM Configuration section) is set as > 2000 connections. Horizontal scaling of the DSR SOAM is not supported or indicated in this release. Please contact Oracle support for additional guidance as needed.

IPFE

Overview

The IPFE was exercised in both VMware and KVM environments. Table 28 shows the measurement capacity of the IPFE. Note that there are three main factors that determine the throughput limits:

- The number of TSAs (one or more) on the IPFE
- Whether there are more than 2,000 connections
- Whether the average message size is less than the MTU size.

Under most conditions the throughput of the IPFE is 2 Gbit/sec. However under the worst case of all three of the above conditions the throughput of the IPFE drops to 1.6 Gb/sec.

When monitoring IPFE capacity both the guest and host CPU utilization should be monitored. Much of the IPFE work is done at the host kernel level so the CPU utilization numbers returned by the IPFE application level don't fully reflect all of the IPFE overhead on the system.

Table 28: IPFE Throughput

	Single TSA on IPFE Pair		Two or more TSAs on IPFE Pair (Total on both TSAs)	
	Avg Msg Size < 1 MTU	Avg Msg Size >= 1 MTU	Avg Msg Size < 1 MTU	Avg Msg Size >= 1 MTU
2,000 Connections or less	2 Gbit/sec	2 Gbit/sec	2 Gbit/sec	2 Gbit/sec
More than 2,000 Connections	2 Gbit/sec	1.6 Mbits/sec	2 Gbit/sec	2 Gbit/sec

Topology



Figure 10. IPFE on Ingress Side Only

Figure 10 shows the typical IPFE configuration, with IPFEs used for “ingress” side traffic between the Diameter clients. This configuration is typical since there are typically many more Diameter clients such as MMEs than there are Diameter servers such as HSSs. The bandwidth numbers given in Table 28 are for the traffic flowing between the clients (MME in the figure above) and the DSR DA-MPs.



Figure 11: IPFE on both Ingress and Egress Sides

Figure 11 shows another possible IPFE configuration where the IPFE uses connection “initiator” functionality to set up the connections between the DA-MPs and the Diameter servers (the HSS simulator in this figure). The IPFE bandwidth requirements need to be calculated separately for the egress side. If all of the DSR traffic goes through an IPFE on both ingress and egress sides, then the required IPFE bandwidth is:

$$(2 * MPS) * (\text{average Diameter message size including IP overhead})$$

Indicative Alarms/Events

In this section, only the key recommended metrics for managing the performance of the IPFE are discussed. There are many more measurements available on the IPFE, and these can be found in [[2]].

Measurements

The key metrics for managing the IPFE VMs are:

Table 29: IPFE Metrics

Measurement ID	Name	Group	Scope	Description	Recommended Usage	
					Condition	Actions
5203	RxIpfesBytes	IPFE Performance	Server Group	Bytes received by the IPFE	If the number of (bytes * 8 bits/byte)/(time interval in s) is > benchmarked capacity (Gbps)	If the traffic is expected to grow then, consider adding an additional IPFE pair
31052	CPU_UtilPct_Average	System	System (IPFE)	The average CPU usage from 0 to 100% (100% indicates that all cores are completely busy)	When running in normal operation with a mate in normal operation, and this measurements exceeds 30% occupancy, OR Exceeds 60% occupancy when running without an active mate.	Contact Oracle
31056	RAM_UtilPct_Average	System	System (IPFE)	The average committed RAM usage as a percentage of the total physical RAM	If the average Ram utilization exceeds 80% utilization	Contact Oracle

Suggested Resolution

Horizontal scaling by adding up to two pairs in total IPFEs per DSR Signaling NE as indicated.

IDIH

Overview

The IDIH (IDIH application, IDIH mediation, IDIH Database VMs) are considered a best effort trouble shooting tool for the DSR. Benchmarking data is not currently provided for the IDIH VMs.

Suggested Resolution

Contact Oracle support.

Appendix A. DSR VM Configurations

The information shown below is a summary of the VM configurations used for the benchmarking data, and the affinity rules for deploying those VMs. Using VM sizes different from these tested values may give unexpected results since the application profiles are tuned to this number of vCPUs and memory sizes. The disk size indicated in Table 26 as storage for each VM is an absolute minimum required to load the DSR images.

Note: If using an Intel 10 Gigabit Ethernet ixgbe driver on the host nodes, note that the default LRO (Large Receive Offload) option must be disabled on the host command line. See the Intel release notes for more details. This action can be performed with the following command.

```
$ sudo ethtool -K <ETH_DEV> lro off
```

Table 30: VM Configurations and Affinity Rules

VM Name	vCPU	RAM (GB)	Disk (GB)	Max Config	Redundancy Models	Affinity/Placement Rules (Per Site)	Notes
DSR NOAM (Regular)	4	6	70	1 Pair	Active/Standby	2 VMs per DSR network in any site. VMs to be deployed on separate servers	

VM Name	vCPU	RAM (GB)	Disk (GB)	Max Config	Redundancy Models	Affinity/Placement Rules (Per Site)	Notes
DSR NOAM (Large)	8	14	70	1 Pair	Active/Standby	2 VMs per DSR network in any site. VMs to be deployed on separate servers	It is recommended to use large NOAM profile if the deployment is more than 32 C level servers. If SOAM profile is large, NOAM profile must be large. In large profiles, the scheduled two measurement exports will run in parallel.
DSR SOAM (Regular)	4	6	70	1 Pair per DSR NF	Active/Standby or Active/Standby/Spare	2 VMs per site. VMs to be deployed on separate servers.	Redundancy model Active/Standby/Spare model is used for PCA mated-pair deployments. For all other deployments Active/Standby model is used.
DSR SOAM (Large)	8	14	70	1 Pair per DSR NF	Active/Standby or Active/Standby/Spare	2 VMs per site. VMs to be deployed on separate servers.	Redundancy model Active/Standby/Spare model is used for PCA mated-pair deployments. For all other deployments Active/Standby model is used. If the diameter connections are higher than 4K, it is recommended to use SOAM large profile. If NOAM profile is large, SOAM profile must be large. In large profiles, the scheduled two measurement exports will run in parallel.
DA MP (Regular)	12	16	70	32 per DSR NF	Active Cluster (N+0)	Should be spread over as many servers as possible to minimize capacity loss on server loss	The limit of 32 is the combined total of DA-MPs, DA-MPs with IWF, DA-MP with EIR and DA-MPs with SCEF. The vSTP MPs and SS7 MPs do not count against this 32. Cannot max out all types in one DSR (for instance 32 DA-MPs AND 32 vSTPs). Any solution using more than 500 ART(Application Route Tables)/ARR(Application Route Rules)+PRR(Peer Route Rules) beyond 20k please use the below profile(DAMP w/ IWF) which is with 24 GB RAM.
DA-MP (Large)	18	24	70	32 per DSR NF	Active Cluster (N+0)	Should be spread over as many servers as possible to minimize capacity loss on server loss	The limit of 32 is the combined total of DA-MPs, DA-MPs with IWF, DA-MP with EIR and DA-MPs with SCEF. The vSTP MPs and SS7 MPs do not count against this 32. Cannot max out all types in one DSR (for instance 32 DA-MPs AND 32 vSTPs). Any solution using more than 500 ART(Application Route Tables)/ARR(Application Route Rules)+PRR(Peer Route Rules) beyond 20k please use the below profile(DAMP w/ IWF) which is with 24 GB RAM.
vSTP MP	8	8	70	32 per DSR NF	Active Cluster (N+0)	Should be spread over as many servers as possible to minimize capacity loss on server loss	The vSTP MPs do not count against the 32 DA-MP limit in a single OCDSR node, so a DSR can have up to 32 vSTP MPs. Cannot max out all types in one DSR (for instance 32 DA-MPs and 32 vSTPs).
Service MP	8	8	70	32 per DSR NF	Active Cluster (N+0)	Should be spread over as many servers as possible to minimize capacity loss on server loss	The service MPs do not count against the 32 DA-MP limit in a single OCDSR node, so a DSR can have up to 32 service MPs. Cannot max out all types in one DSR (for instance 32 DA-MPs and 32 service MPs).

VM Name	vCPU	RAM (GB)	Disk (GB)	Max Config	Redundancy Models	Affinity/Placement Rules (Per Site)	Notes
IPFE	6	16	70	2 pairs per DSR NF	Active/Standby	Each VM in a pair must be deployed on separate server	Deployed in pairs. Max 2 pairs (4 VMs).
SS7 MP	12	24	70	8 per DSR NF	Active Cluster (N+0)	Should be spread over as many servers as possible to minimize capacity loss on server loss	
SBR(s)	12	25	70	8 Server Groups per SBR(s)	Active/Standby/Spare	Active/Standby VMs to be deployed on separate servers, Spare is typically at another geographic location for geo-redundancy	Can be either Active/Standby/Spare or Active/Standby depending on customer geo-redundancy requirements.
SBR(b)	12	32	70	8 Server Groups per SBR(b)	Active/Standby/Spare	Active/Standby VMs to be deployed on separate servers, Spare is typically at another geographic location for geo-redundancy	Can be either Active/Standby/Spare or Active/Standby depending on customer geo-redundancy requirements.
SBR(u)	12	24	70	64 Server Groups per SBR(b)	Active/Standby/Spare	Active/Standby VMs to be deployed on separate servers, Spare is typically at another geographic location for geo-redundancy	Can be either Active/Standby/Spare or Active/Standby depending on customer geo-redundancy requirements.
DP SOAM (Regular)	4	12	125	1Pair per DSR NF	Active/Standby	2 VMs per site. VMs to be deployed on separate servers	
DP (Regular)	6	10	125	10 per DSR NF	Active Cluster (N+0)	Should be spread over as many servers as possible to minimize capacity loss on server loss	To be evenly distributed across servers to minimize capacity loss
SDS NOAM (Regular)	4	32	300	1 Pair per Network	Active/Standby	Anti-affinity between the Active/Standby VMs	Active/Standby. An optional "Disaster Recovery" SDS is supported that would typically be located at a different data center to provide geo-redundancy.
Query Server (Regular)	4	32	300	1 per SDS NOAM	N/A since non-redundant	Non, non-redundant	Optional 1 per site. Can have one for the primary SDS-NOAM and one for the Disaster Recovery SDS-NOAM
DP SOAM (Large)	4	64	400	1Pair per DSR NF	Active/Standby	2 VMs per site. VMs to be deployed on separate servers	Supports
DP (Large)	24	64	400	10 per DSR NF	Active Cluster (N+0)	Should be spread over as many servers as possible to minimize capacity loss on server loss	To be evenly distributed across servers to minimize capacity loss
SDS NOAM (Large)	4	128	840	1 Pair per Network	Active/Standby	Anti-affinity between the Active/Standby VMs	Active/Standby. An optional "Disaster Recovery" SDS is supported that would typically be located at a different data center to provide geo-redundancy.
Query Server (Large)	4	128	840	1 per SDS NOAM	N/A since non-redundant	Non, non-redundant	Optional 1 per site. Can have one for the primary SDS-NOAM and one for the Disaster Recovery SDS-NOAM

VM Name	vCPU	RAM (GB)	Disk (GB)	Max Config	Redundancy Models	Affinity/Placement Rules (Per Site)	Notes
UDR NO	14	64	400	n (Active, Standby)	Active/Standby/Spare	Active/Standby/Spare VMs to be deployed on separate servers, Spare is typically at another geographic location for geo-redundancy	Redundancy model Active/Standby/Spare model is used. Active/Standby on Site 1 and Spare on Site 2. UDR is scaled by adding UDRNOs. The Standby UDR NO also receives query traffic from STP-MP and DA-MP.
API Gateway App Server	12	16	70	32 per DSR NF	Active Cluster (N+0)	Should be spread over as many servers as possible to minimize capacity loss on server loss.	Optional component. For SCEF deployments only.
API Gateway Admin Server	4	6	70	1 per DSR NF	Active	None, non-redundant	Optional component. For SCEF deployments only.
API Gateway DB server	4	6	70	1 pair per DSR NF	Active/Standby	Active/Standby VMs to be deployed on separate servers.	Optional component. For SCEF deployments only.
VNFM	8	10	80	NA	N/A since non-redundant	None, non-redundant	VNF Manager deployment
SPF+NRF	2	4	30	NA	N/A since non-redundant	None, non-redundant	Optional component. 5G apps deployment only.
iDIH Application	4	8	64	1 per Site	N/A since non-redundant	None, non-redundant	Optional component for Diameter traffic monitoring
iDIH Mediation	4	8	64	1 per Site	N/A since non-redundant	None, non-redundant	Optional component for Diameter traffic monitoring
iDIH Database	4	8	120GB + 100GB (ephemeral)	1 per Site	N/A since non-redundant	None, non-redundant	Optional component for Diameter traffic monitoring

Appendix B. DSR VM Disk Requirements

This section provides guidance on the disk requirements for the OCDSR VMs. Characterizing disk requirements can be tricky since there are many variables that can affect disk usage, such as how many reports are being run on the OAM systems, or how often backups are run. Peak disk utilization can also very different from average disk utilization, for instance during backups or restore operations. While these guidelines are provided for the disk usage of the different VM types, customers should verify their disk usage under their own conditions since they are more driven by how the customer uses their system than by easier to calculate factors such as CPU utilization per MPS.

The OCDSR has been designed as a low disk-utilization application, with all critical call processing applications performed in memory. There is also no swap disk utilization in any of the VMs. As a background for all of these numbers, the OCDSR has been run for years on “bare metal” deployments with a single pair of industry-standard 10k RPM, 2½ inch disk drives in Raid 1. So even maximum sized OCDSR configurations run successfully on the approximately 120 IOPs provided by those disks. When run on higher-performance disk subsystems such as SSDs, high disk utilization tasks such as background report generation just complete faster. The notes for each VM type give some of the factors that can drive different disk utilization levels. For instance, the primary traffic handling VMs, the IPFEs and the different types of MPs, have a fairly constant disk utilization independent of the traffic level. This is because the primary disk utilization is for saving statistics, then forwarding them to the SOAM.

Table 31: VM Disk Utilization Characteristics

VM Name	Disk (GB)	Routine Disk Utilization (IOPs) ¹	Peak Disk Utilization (IOPs) ²	Disk Usage Modes	Notes
DSR NOAM	70	100	800	Periodic (30 second) small writes to collect statistics. Large block reads to run reports and backups.	Background disk utilization is mostly statistics collection from managed DSRs. Peak disk utilization driven by customer report generation and maintenance activities such as backups.
DSR SOAM	70	100	800		
DA MP	70	50	500	Writes statistics to disk at 30 second intervals, reads them at 5 minute intervals to send to SOAM	Disk utilization is independent to traffic levels. Is affected by the size of the DSR configuration (number of connections for instance) and the utilization of features that create measurements such as ETGs and TTPs.
DA MP w/IWF	70	50	500		
vSTP MP	70	50	500		
SS7 MP	70	50	500		
IPFE	70	20	100		
SBR(s)	70	50	800	Disk writes mostly short bursts for statistics storage	Peak disk utilization driven by recovery activities between active/standby servers.
SBR(b)	70	50	800		
SBR(u)	70	50	800		
SDS NOAM	300	100	800	Synchronizes changes to in-memory database to disk. Mostly write application	SDS can maintain multiple copies of large subscriber database. Peak disk utilization is mostly driven by creating new backups.
DP SOAM	125	50	800		
DP	125	80	500		
Query Server	300	100	800	Synchronizes changes to in-memory database to disk. Reads are driven by customer queries	The query server is not a real-time system. The amount of disk reads is driven entirely by manual customer database queries.

¹ The “routine” disk utilization is the minimum engineered IOPs for the proper functioning of the VM. Average disk utilization is typically lower.

² The “Peak” disk utilization is number of IOPs the VM is capable of using given sufficient resources.

Appendix C. VM Networking Requirements

This section gives information on the networking characteristics of the different VMs. The traffic is broken down into signaling traffic handled on the XMI network, and OAM traffic carried on the IMI and XMI networks.

The Diameter Traffic requirements on the XSI networks can be calculated from the MPS. Treating the OCDSR as black box, this network traffic is simply the average Diameter message size (for requests and answers) times the MPS rate for the OCDSR node. The complication is that some Diameter traffic is likely to go through both an ingress DA-MP and an egress DA-MP. The most conservative consumption is that any ingress message is equally likely to go out any of the DA-MPs. Thus if a DSR has X DA-MPs, and Y total MPS per DA-MP, the average Diameter signaling traffic through a DA-MP is:

$$((\text{Average Diameter message size including IP overhead}) * Y) * (1 + ((2X-1)/X))$$

As an example, if the average Diameter message size is 2,000 bytes including overhead, the overall DSR MPS is 10,000 MPS, and the number of DA-MPs is three, the calculation would be:

$$(2,000 \text{ bytes} * 8 \text{ bits/byte} * 10,000 \text{ MPS}) * (1 + (2 * 3 \text{ DA-MPs}) - 1) / (3 \text{ DA-MPs}) = (160,000 \text{ kb/s}) * (2.66) = 426,666 \text{ kb/s per DA-MP}$$

For the MP types other than the DA-MPs simply substitute the average size of signaling types, for instance SS7 messages for the vSTP MP. Since typically SS7 messages are much smaller than Diameter messages (for instance ~200 bytes for SMS), the vSTP MP bandwidth is much smaller than the DA-MP bandwidth.

The OAM traffic on the VMs can be much more variable since it's dependent to customer-specific usage patterns such as the number of reports requested and the number of periodic activities such as backups and restores. The notes for each VM type give some background on the network impacts of these customer-driven activities.

Table 32: VM Networking Utilization Characteristics

VM Name	Networks Supported	Management Networks (Gb/s)	Traffic Networks (Gb/s)	Notes
DSR NOAM	XMI IMI	2	N/A	Activities such as backups can generate higher network utilization, but runs at the rate of the bandwidth available since they are not real-time activities.
DSR SOAM		1		
DA MP	XMI IMI XSI	0.2	MPS Dependent	See explanation above for how to calculate the signaling network traffic.
DA MP w/IWF				
vSTP MP				
SS7 MP				
IPFE	XMI IMI XSI	0.2	MPS Dependent	The peak networking capacity supported by the IPFE is 3.2 Gb/s. Typically the IPFE is deployed only on the ingress (towards clients such as MMEs) side of the DA-MP, so the total traffic through the IPFE is ½ the total bandwidth of the DA-MPs.
SBR(s)	XMI IMI	1.0	N/A	The given OAM bandwidth is for routine operations. Some recovery operations such as synchronizing the database between the active and standby servers after a prolonged disconnection can consume an order of magnitude or more of network bandwidth. The required amount of bandwidth for these recovery operations is very dependent on customer-factors such as number of subscribers, the MPS rate, and the amount of networking downtime.
SBR(b)				
SBR(u)				
SDS NOAM	XMI IMI	1.0	N/A	The maximum bandwidth required by the SDS NOAM is determined primarily by the provisioning rate from external customer systems along with the size of the customer records.
DP SOAM	XMI IMI	1.0	N/A	All of the subscriber data provisioned at the SDS NOAM is passed down to each DP SOAM, which then distributes the data to any attached DPs.
DP	XMI IMI	1.0	N/A	The DP receives writes of new subscriber records from the SOAM, and database queries from the DA-MPs.

VM Name	Networks Supported	Management Networks (Gb/s)	Traffic Networks (Gb/s)	Notes
Query Server	XMI IMI	1.0	N/A	The Query Server is synchronized to the changes in the SDS NOAM. In addition there is some network traffic due to customer search requests, but this traffic is small compared to the synchronization traffic.
UDR NO	XMI IMI XSI	1.0	N/A	UDR NO receives internal query from STP MP and DA MP

Table 33 shows some guidelines for mapping the logical OCDSR networks (XMI, IMI, etc.) to interfaces. There is nothing fixed about these assignments in the application, so they can be assigned as desired if the customer has other requirements driving interface assignment.

Table 33: Typical OCDSR Network to Device Assignments

VM Name	OAM (XMI)	Local (IMI)	Signaling A (XSI1)	Signaling B (XSI2)	Signaling C (XSI3)	Signaling (...)	Signaling D (XSI6)	Replication (SBR Rep)	DIH Internal
DSR NOAM	eth0	eth1							
DSR SOAM	eth0	eth1							
DA-MP	eth0	eth1	eth2	eth3	eth4		eth17	eth18	
IPFE	eth0	eth1	eth2	eth3	eth4		eth17		
SS7 MP	eth0	eth1	eth2	eth3	eth4		eth17	eth18	
SBRB	eth0	eth1						eth2	
SBR S	eth0	eth1						eth2	
SBR U	eth0	eth1						eth2	
vSTP	eth0	eth1	eth2	eth3	eth4		eth17		
UDRNO	eth0	eth1	eth2	eth3	eth4		eth17		
iDIH App	xmi								int
iDIH Med	xmi	imi							int
iDIH DB	xmi								Int
SDS NOAM	eth0	eth1							
SDS NOAM	eth0	eth1							
DP	eth0	eth1							
Query Server	eth0	eth1							
API Gateway Admin (OC SG)	eth0	eth1							
API Gateway App Server (OC SG)	eth0	eth1	eth2	eth3	eth4		eth17		
API Gateway DB (OC SG)	eth0	eth1							

Appendix D. Summary of Benchmark Data Recommendations

The information shown below is a summary of the benchmark data described throughout the document. This data is intended to provide guidance, and is based solely on the observed results from the test setups described in this document. Recommendations may need to be adapted to the conditions in a given operator's cloud, such as differences in traffic patterns, feature utilization patterns, and infrastructure differences.

Table 34: Benchmark Data Summary

Benchmark Run	VMware/ESXi	Openstack/KVM
Application Software	DSR 8.3 (running Oracle Linux)	DSR 8.3 (running Oracle Linux)
Host VM	VMware 6.0	OpenStack Mitaka, Newton/KVM
HW	Oracle Server X5-2	Oracle Server X5-2, HP Gen9v1
VM Profiles/Flavors	DSR VM Configurations	DSR VM Configurations

Table 35: Recommended Maximum Engineering Targets

VM Name	VM Purpose	Recommended Maximum Engineering Targets	
		Unit	Quantity
DSR NOAM	Network Operation, Administration, Maintenance (and Provisioning)	VM	1+1
DSR SOAM	Site (node/Network Element) Operation, Administration, Maintenance (and Provisioning)	VM	1+1
DA MP (Relay) (Regular Profile)	Diameter Agent Message Processor	MPS	18,000
DA MP (Relay) (Regular Profile) configuration set to DOC/CL1/CL2 discards set to 0 and multi queuing enabled on all hosts	Diameter Agent Message Processor	MPS	36,000
DA MP (Relay) (Large Profile)	Diameter Agent Message Processor	MPS	35,000
DA MP (Database)	Diameter Agent Message Processor	MPS	16,000
DA MP (Statefull)	Diameter Agent Message Processor	MPS	13,000
DA MP w/ EIR	Diameter Agent Message Processor for EIR application	MPS	2000

VM Name	VM Purpose	Recommended Maximum Engineering Targets	
		Unit	Quantity
DA MP w/ SCEF	Diameter Agent Message Processor for SCEF application	MPS	5000
vSTP	Virtual STP for M3UA and M2PA message Processing	MPS	20,000
vSTP w/ EIR	Virtual STP Message processor with EIR application	MPS	5000
Service MP	Service MP is used for SMS home proxy feature	MPS	21000 MO
			10000 MO + 5000 MT
IPFE	IP Front End	Gb/s per IPFE pair	2.0 ¹
		Connections per IPFE Pair per TSA	2,000
		Target Set Address (TSA) per IPFE pair	32
SS7 MP	SS7 Message Processor for MAP Diameter interworking function	MPS	12,000
SBR(s) (Single Server Group)	Subscriber Binding Repository (session) for Policy DRA	Diameter sessions	16,000,000
		MPS	50,000
SBR(s) (Max 8 Server Groups)	Subscriber Binding Repository (session) for Policy DRA	Diameter sessions	128,000,000
		MPS	400,000
SBR(b) (Single Server Group)	Subscriber Binding Repository (binding) for Policy DRA	Subscriber Bindings	16,000,000
		MPS	50,000
SBR(b) (Max Network-wide with 8 Server Groups)	Subscriber Binding Repository (binding) for Policy DRA	Subscriber Bindings	128,000,000
		MPS	400,000
SBR(u) (Single Server Group)	Subscriber Binding Repository (universal) for SCEF	Context Information	5,000,000
		MPS	16,000
SBR(u) (Max 64 Server Groups)	Subscriber Binding Repository (universal) for SCEF	Context Information	320,000,000
		MPS	1,024,000
DP SOAM	Database Processor Site (node) Operation, Administration, Maintenance for address resolution and subscriber location functions	VM	1+1

VM Name	VM Purpose	Recommended Maximum Engineering Targets	
		Unit	Quantity
DP	Database Processor for address resolution and subscriber location functions	MPS requiring DP lookups (usually 50% of FABR traffic)	80,000
SDS	Subscriber Database Processor for address resolution and subscriber location functions	Routing Entities (typically 2x subscriber count)	300,000,000
		NAI User Routing Entries	500,000
		Provisioning TPS	200
		XML Interface reads/second	200
Query Server	Allows customers to query FABR subscriber data via a MySQL interface	N/A	N/A
UDR NO	User Data Repository for vEIR message Processing	MPS	12,500
		Max Number of Subscribers	100,000,000

¹ See also Table 28 for factors that can lower this number.

Appendix E. Detailed Infrastructure Settings

Table 36: Detailed Infrastructure Settings

Attribute	KVM/Oracle X5-2	HP Gen9v1
Model	Oracle Server X5-2	ProLiant DL380c Gen9v1
Processor Type	Intel® Xeon® CPU E5-2699 v3 @ 2.30GHz	Intel(R) Xeon® CPU E5-2680 v3 @ 2.50GHz
vCPUs	72 [2 CPU Sockets [18 x 2 Cores, each with Hyper threading Active]	48 [2 CPU Sockets [12 x 2 Cores, each with Hyper threading Active]
RAM	128 G [DDR4-2133]	256 GB (DDR4-2133)
CPU Cache Memory	45 MB (Intel® Smart Cache)	30MB (Intel® Smart Cache)
Number and Type of NICs	4 [Intel Corporation Ethernet Controller 10-Gigabit X540-AT2]	2 x HP 10Gb 2-port 560M Adapter
BIOS Power Settings	Power Supply Maximum: Maximum power the available PSUs can draw Allocated Power: Power allocated for installed and hot pluggable components Peak Permitted: Maximum power the system is permitted to consume (set to Allocated Power)	HP Static High Performance Mode
HDD	2.3 TB of solid state drive (SSD) storage	HP Smart Array P244br Controller Disk Drive Interface 6Gb/s SAS (Serial Attached SCSI) 2 x HP 900GB 12G SAS 10K rpm SFF (2.5-inch) SC Enterprise

Appendix F. Small DSR VM Configuration

Many customers don't need the capacity provided by even a single pair of standard size DSR DA-MP VMs. The fixed configuration in this section is for customers that only need:

- Relay or RBAR applications
- 6k MPS or less (assuming an infrastructure equal to or better than the X5-2 processors used for the benchmark tests).
- 5K or less RBAR entries
- No IPFE

This configuration should be run with the 6k DA-MP profile.

Table 37: Minimal System VM Configurations and Affinity Rules

VM Name	vCPU	RAM (GB)	Disk (GB)	Max Config	Redundancy Models	Affinity/Placement Rules (Per Site)	Notes
DSR NOAM	4	6	70	1 Pair	Active/Standby	2 VMs per DSR network in any site. VMs to be deployed on separate servers if possible	Two NOAMs are always required to support upgrades, but they can be on the same server if only one server is available.
DSR SOAM	4	6	70	1 Pair per DSR NF	Active/Standby		
DA MP	4	8	70	1 or 2 per DSR NF	1 or 1+1	The 1+1 configuration should have the DA-MPs on different servers	There's little value in have redundant DA-MPs (1+1) if they are on the same server since the server is the thing most likely to fail.

Appendix G. DSR DA-MP Profiles

DA-MP profiles are used to set various parameters associated with performance of the DA-MP such as:

- Internal resource allocations such as the number of various types of threads created by that VM.
- The absolute limit of traffic that a DA-MP can handle set to 2.5 times the stated capacity of the VM.
- Fixed alarms for various traffic conditions such as message rates, average message sizes and hold times.
- User-configurable values for message discard percentages at the different DA-MP congestion levels.

The throughput of a DA-MP is determined by the CPU and infrastructure, not by the Profile assigned to it. Assigning a higher profile does not increase the throughput of a DA-MP, and may hurt it. For perspective, if you apply all of the factors below to the X5-2 system used in the benchmarks running 100% relay, you get the recommended capacity of 18k MPS per DA-MP. Thus all of the benchmarks in this document were run with the 18k profile.

In the cloud environment the correct profile should be selected based on the expected DA-MP throughput. This throughput is based on three major factors:

- The performance of the customer's infrastructure relative to the infrastructure used for the benchmarking described in this document.
- The mix of application types (relay, database, session) being run on the DA-MP.
- The VM configuration such as the number of vCPUs.

These factors are useful for estimating the VM performance in advance, but the customer should also monitor the actual performance of the different VM types using the KPIs, alarms, and measurements described for each VM type in the previous sections.

Infrastructure Performance Differences

The benchmarks in this document were done on Oracle X5-2 servers configured with Intel Xeon X5-2699v3 processors. When trying to estimate the performance of a different type of server with a different processor type, the main factor is the single threaded performance of the chip, such as SPECint@ 2006 from Spec.org. The overall performance of the server/chip is less important since the VM configurations assign the same number of vCPUs/threads to the VM independent of the number of threads supported by processor (for example, you can get more VMs on a server with more vCPUs, but the performance for a given number of vCPUs is set by the single-thread performance). Historically, within a couple of Intel processor generations, the performance of the OCDSR VMs varies relatively linearly with the difference in single-thread performance, for example, a processor with a SPECint2006 rating of 66 has 10% better OCDSR performance than a processor with a SPECint2006 rating of 60.

Traffic Mix

The different classes of applications tested (Relay, Database, Statefull) have significantly different MPS results for a fixed infrastructure configuration (server type, VM size). The capacity for an OCDSR running a mixture of these types can be calculated by using percentage of traffic of a given type. For example, using the values from Table 34, consider an OCSR with the following traffic mix:

- Relay 40% (18k MPS)
- Database (30%) (16k MPS)
- Statefull (30%) (13k MPS)

The effective throughput for this traffic mix would be:

$$(40\%*18k) + (30\%*16k) + (30\%*13k) = 15.9k \text{ MPS}$$



The caveat to this calculation is that the percentage for the lower performing traffic types (Database and Statefull) should reflect their worst case values, for instance to handle traffic spikes of that traffic type caused by failure conditions of other components in the network.

The performance of the vSTP application is calculated separately since it has dedicated MPs that run only vSTP traffic.

VM Configuration

The tested VM configurations are given in Section DSR VM Configurations and Section DSR DA-MP Profiles. It's recommended that these VM configurations are used as tested for the most predictable results. If for some reason the customer desires to change them for a given installation, here are some guidelines that should be kept in mind:

- The installation and upgrade procedures for the VMs requires a minimum of 70GB of disk storage. While assigning less storage than this may appear to work during installation, it will likely cause failures during the upgrade procedures.
- The IWF function requires 24 GBs of memory to run. It does not come into service with any smaller memory allocation.
- Adding vCPUs to the configurations may increase performance, but only up to a point since there may not be enough threads to efficiently take advantage of the extra vCPUs.
- Reducing the vCPU counts should not be done for any VM except for the DA-MPs. The issue is that configurations that appear to run fine under normal traffic conditions may not have sufficient capacity under recovery conditions or under heavy loads (for instance running reports on a SOAM while it's doing a backup). The DA-MP vCPU number should not be lower than 4 vCPUs (see section Small DSR VM Configuration for an example small DSR configuration.)

Selecting a DA-MP Traffic Profile

The following DA-MP traffic profiles for cloud deployments are supported in OCDSR 8.5:

- 6k MPS
- 8k MPS
- 12k MPS
- 14k MPS
- 16k MPS
- 18k MPS
- 21k MPS
- 24k MPS
- 27k MPS
- 30k MPS
- 35k MPS
- 40k MPS

It is possible to change the DA-MP profile assigned to a DA-MP VM, however, the DA-MP application has to be restarted for it to take effect. Since the results of the traffic mix calculation and any adjustments due to different processor performance are unlikely to land exactly on any of these numbers, the question is whether to use the next larger or next smaller DA-MP profile. In general, selecting the next larger DA-MP



profile (for instance selecting the 16k MPS profile for the 15.9k MPS calculated in the Traffic Mix) provides the best solution. However, here are some considerations:

- While the larger profiles assign more system resources (message buffers, etc.) the differences between these resource allocations between any two consecutive profiles is relatively small (proportional to their MPS difference or about typically about 20%). Since these allocated system resources are a relatively small portion of the over VM memory usage (which includes, for instance, the resources used by the Guest OS and the base OCDSR application), assigning the higher rated profile ensures sufficient resource allocation. The standard VM profiles provided in DSR VM Configurations section have sufficient memory to support up to the 24k MPS profiles. Above that level, additional memory may be required depending on the traffic mix.
- Over a small range of DA-MP profiles (plus or minus one at least), the DA-MP profile likely has no impact on the actual throughput of the VM. The DA-MP overload controls are driven by CPU percentage (that is, actual utilization), not by any of these calculations. The only hard limit on the throughput of a given profile is 250% of the nominal value. For instance, the 10k MPS DA-MP profile starts shedding traffic (using the same algorithms as DA-MP overload) at 25k MPS, even if the CPU percentage has not hit the CPU utilization level required to trigger the CL1 congestion level.
- Selecting the DA-MP profile just under the calculated MPS capacity (for example, selecting the 14k DA-MP profile for the 15.9k MPS calculated in the Traffic Mix) causes the various system alarms to happen earlier. For instance, the minor traffic alarm triggers at 8400 MPS (60% of 14k) instead of at 9200 MPS (60% of 16k) if the next larger profile was selected. Thus selecting the smaller DA-MP profile (14k, in this example) provides more conservative alarming, and the higher profile (16K MPS) provides less conservative alarming. But, as noted in the previous item, it does not affect the actual throughput of the VM since that is driven by CPU usage.
- Selecting a DA-MP profile that is a lot larger than the nominal capacity calculated in the previous section does not increase the throughput of the VM, and causes the capacity alarms to trigger later than expected. Selecting a DA-MP profile that is a lot smaller than the nominal capacity causes the alarms to trigger sooner than expected, and may limit the capacity of the VM due to insufficient system resources being allocated.